

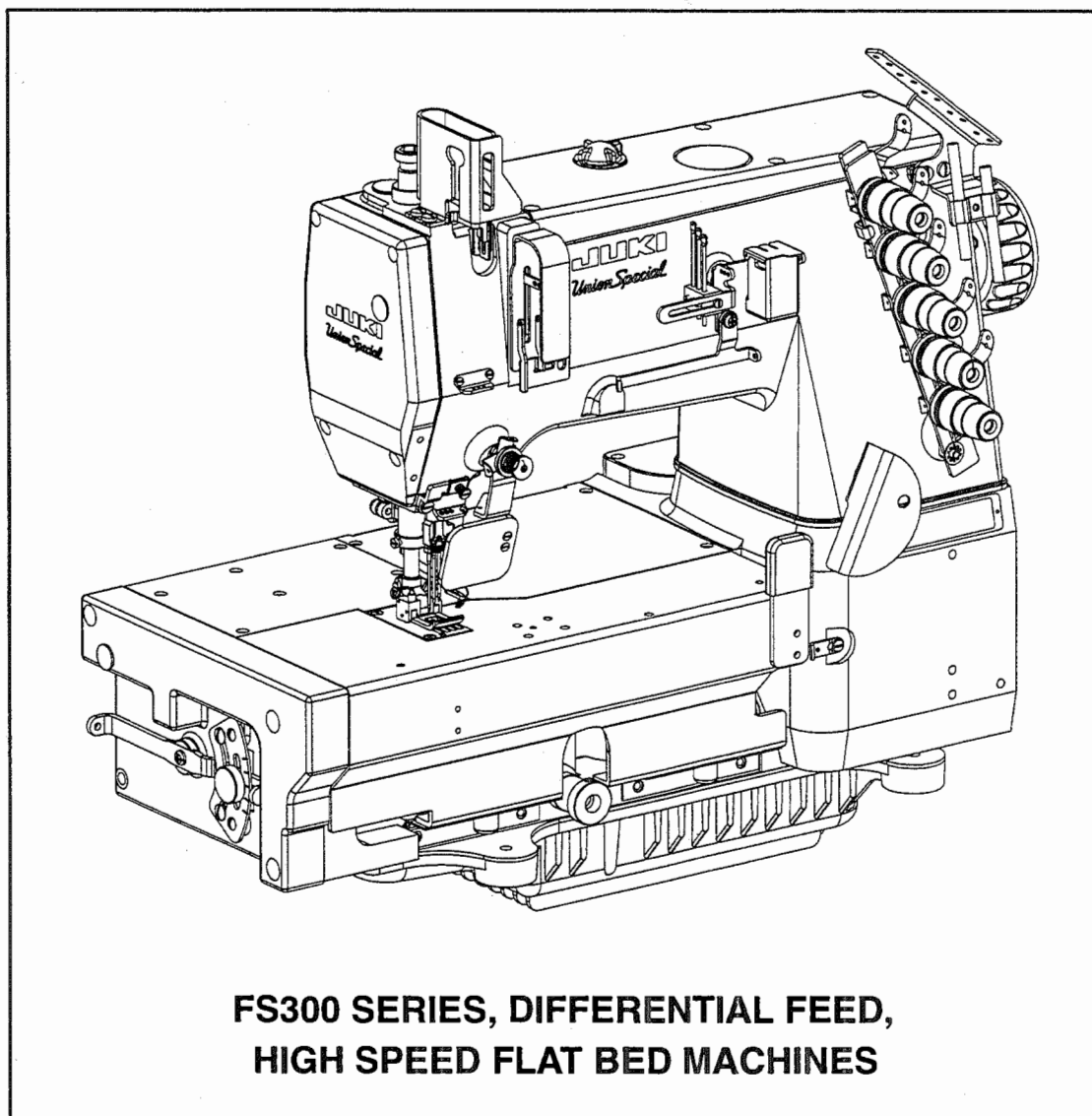

Finest Quality

*Union Special*  
INDUSTRIAL SEWING EQUIPMENT

**ILLUSTRATED PARTS MANUAL**



**FS300 SERIES, DIFFERENTIAL FEED,  
HIGH SPEED FLAT BED MACHINES**

**MANUAL NO. PT9643**

**FOR DEVICE**

**UT12AFS3**

**UT13AFS3**

# Parts Manual PT9643 for Devices UT13AFS3, UT12AFS3

Fourth Edition Copyright 1997 by Union Special Corporation  
Rights Reserved In All Countries Printed in U.S.A. September 1998

## PREFACE

This parts manual has been prepared to assist you in locating NEW individual parts or assemblies on the FS300 Series machines. It can be used in conjunction with Union Special Parts Manuals PT9800, (depending on machine style), Operator's Manual OP9614 & Engineer's Manual EN9424.

It is the desire of Union Special that each machine run at its optimum performance. Parts listed in this manual are designed specifically for your machine and are manufactured with utmost precision to assure long lasting service.

## CONTENTS

PREFACE .....	2
SAFETY RULES .....	3
FABRIC THREAD TRIMMER ADJUSTMENTS .....	4
FABRIC THREAD TRIMMER ADJUSTMENTS .....	5
FABRIC THREAD TRIMMER ADJUSTMENTS .....	6
SOLENOID/PNEUMATIC THREAD WIPER .....	7
ADJUSTING THREAD WIPER .....	8
PNEUMATIC COVER THREAD TRIMMER .....	9
TENSION RELEASE (UNDERBED THREAD TRIMMER) .....	10
THREAD PULL-OFF .....	11
THREAD TENSION .....	13
FABRIC THREAD TRIMMER ASSEMBLY .....	15
MISCELLANEOUS PARTS UT12FS3 .....	17
MISCELLANEOUS PARTS UT13FS3 .....	19
PNEUMATIC SPREADER THREAD TRIMMER ASSEMBLY .....	21
PRESSER FOOT LIFTER ASSEMBLY .....	23
PNEUMATIC CONTROL ASSEMBLY .....	25
NUMERICAL INDEX OF PARTS .....	26
NOTES .....	27



## SAFETY RULES

1. Before putting the machines described in this manual into service, carefully read the instructions. The starting of each machine is only permitted after taking notice of the instructions and by qualified operators.

**IMPORTANT!** Before putting the machine into service, also read the safety rules and instructions from the motor supplier.

2. Observe the national safety rules valid for your country.
3. The sewing machines described in this instruction manual are prohibited from being put into service until it has been ascertained that the sewing units which these sewing machines will be built into, have conformed with the EC Council Directives (89/392/EEC, Annex II B).

Each machine is only allowed to be used as foreseen. The foreseen use of the particular machine is described in paragraph "STYLES OF MACHINES" of this instruction manual. Another use, going beyond the description, is not as foreseen.

4. All safety devices must be in position when the machine is ready for work or in operation. Operation of the machine without the appertaining safety devices is prohibited.
5. Wear safety glasses.
6. In case of machine conversions and changes all valid safety rules must be considered. Conversions and changes are made at your own risk.
7. The warning hints in the instructions are marked with one of these two symbols:



8. When doing the following the machine has to be disconnected from the power supply by turning off the main switch or by pulling out the main plug:
  - 8.1 When threading needle(s), looper, spreader etc.
  - 8.2 When replacing any parts such as needle(s), presser foot, throat plate, looper, spreader, feed dog, needle guard, folder, fabric guide etc.
  - 8.3 When leaving the workplace and when the workplace is unattended.
  - 8.4 When doing maintenance work.
  - 8.5 When using clutch motors without actuation lock, wait until the motor is stopped totally.
9. Maintenance, repair and conversion work (see item 8) must be done only by trained technicians or special skilled personnel under consideration of the instructions.
10. Any work on the electrical equipment must be done by an electrician or under direction and supervision of special skilled personnel.
11. Work on parts and equipment under electrical power is not permitted. Permissible exceptions are described in the applicable sections of standard sheet DIN VDE 0105.
12. Before doing maintenance and repair work on the pneumatic equipment, the machine has to be disconnected from the compressed air supply. In case of existing residual air pressure after disconnecting from compressed air supply (i.e. pneumatic equipment with air tank), the pressure has to be removed by bleeding.



## FABRIC THREAD TRIMMER ADJUSTMENTS

Loosen screws (D Fig 1-A) just enough so bracket (A Fig 1-B) moves firmly against support (B Fig 1-B).

Make all adjustments with the needle bar at top dead center. This can be checked by lining up the spot on the casting with the spot on the handwheel.

With the klipp-it attached to the machine with screws (C Fig 1-B) extend the lower knife 3mm past the right end of the looper. Align the tip of the lower knife so it is centered over the flat on top of the looper as shown in Fig 1-B. Tighten screws (C Fig 1-B).

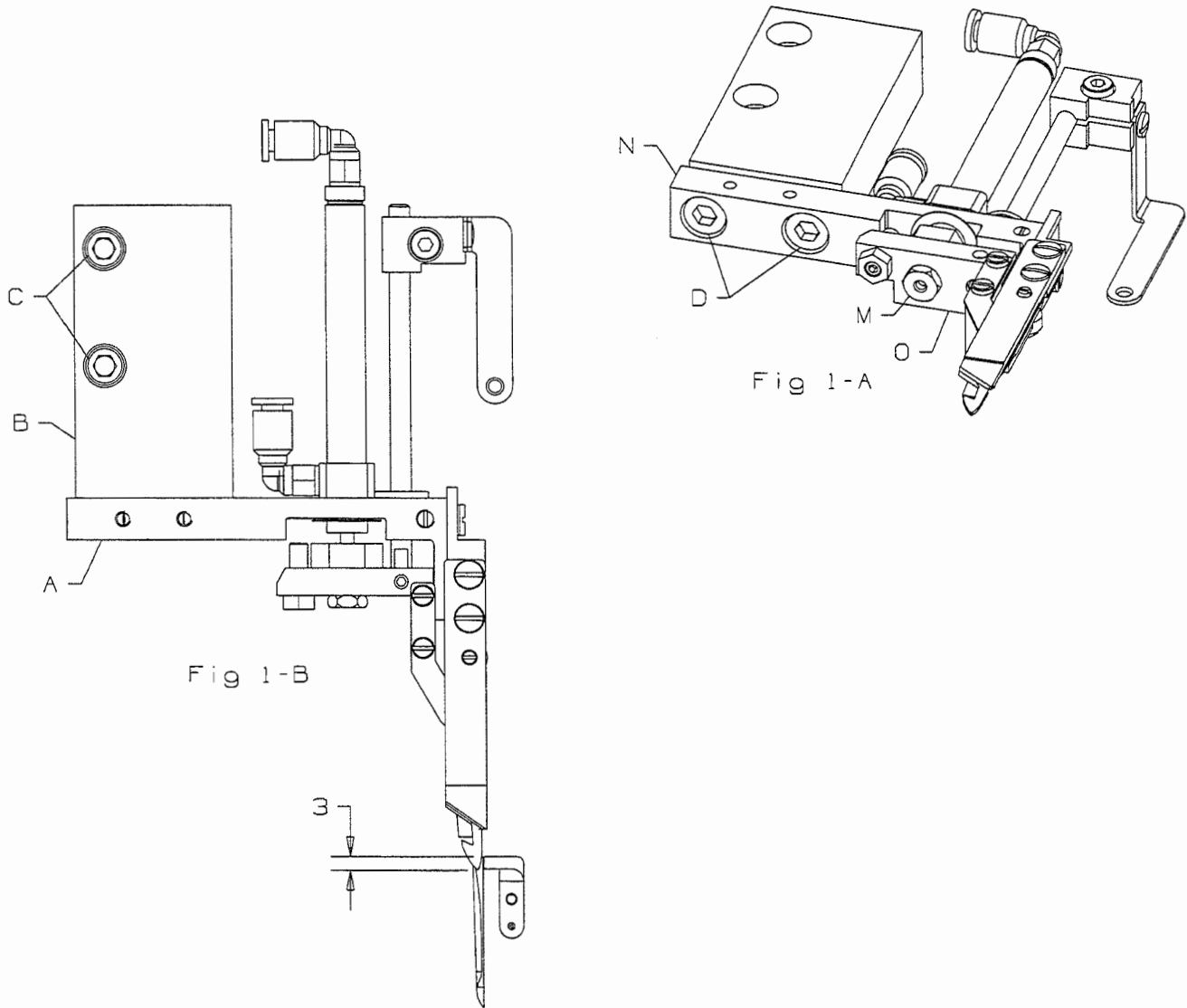

NOTE: If the air cylinder is ever removed, when reinstalling make sure the top surface of bracket (N Fig 1-A) is parallel to the top surface of (O Fig 1-A). Lock the position in place using screw (M Fig 1-A). This will keep the upper and lower knives parallel for best cutting.



## FABRIC THREAD TRIMMER ADJUSTMENTS

Loosen screws (E Fig 2-A) and adjust the upper knife to be 7.5mm from the feed dog (Fig 2-B). Retighten screws (E Fig 2-A) and make sure no up or down pressure is applied to the lower knife, try to make both knives as parallel as possible by eye.

Adjust the home position so the upper knife is overlapping the lower knife by .5mm (Fig 2-A). Adjust this using screw (G Fig 20A) and then lock in place with nut (H Fig 2-A).

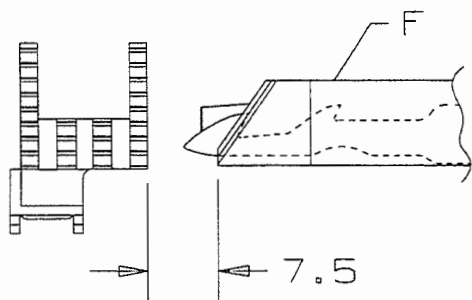

Fig 2-B

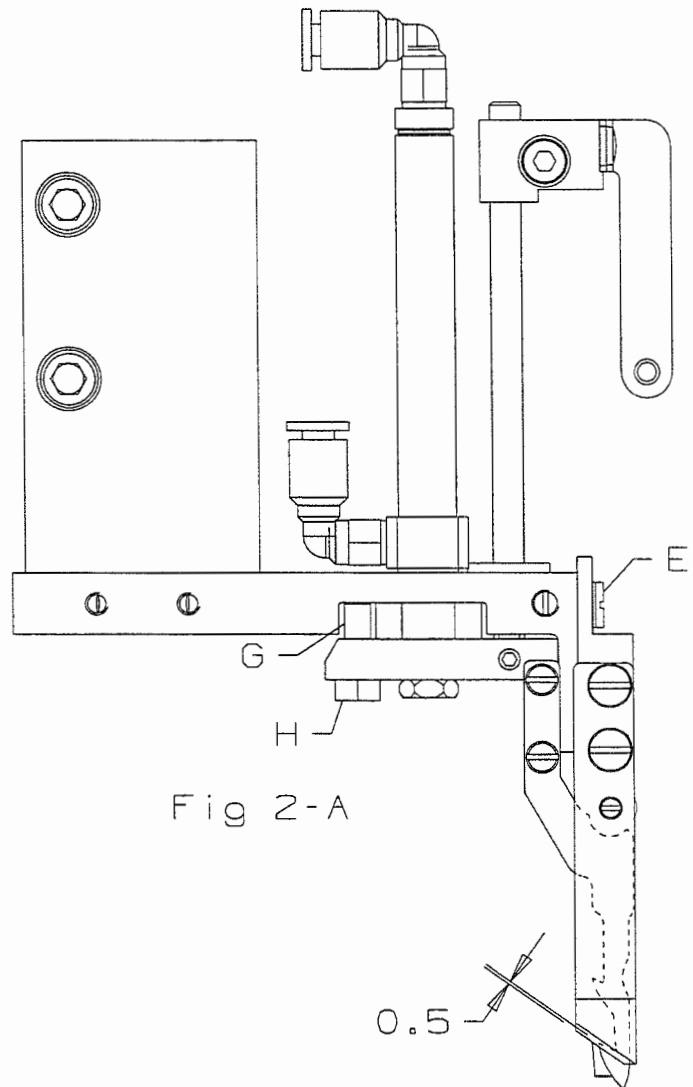
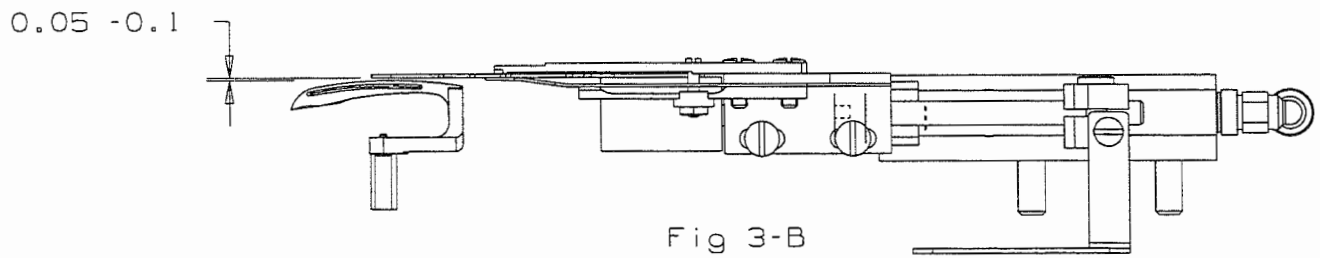
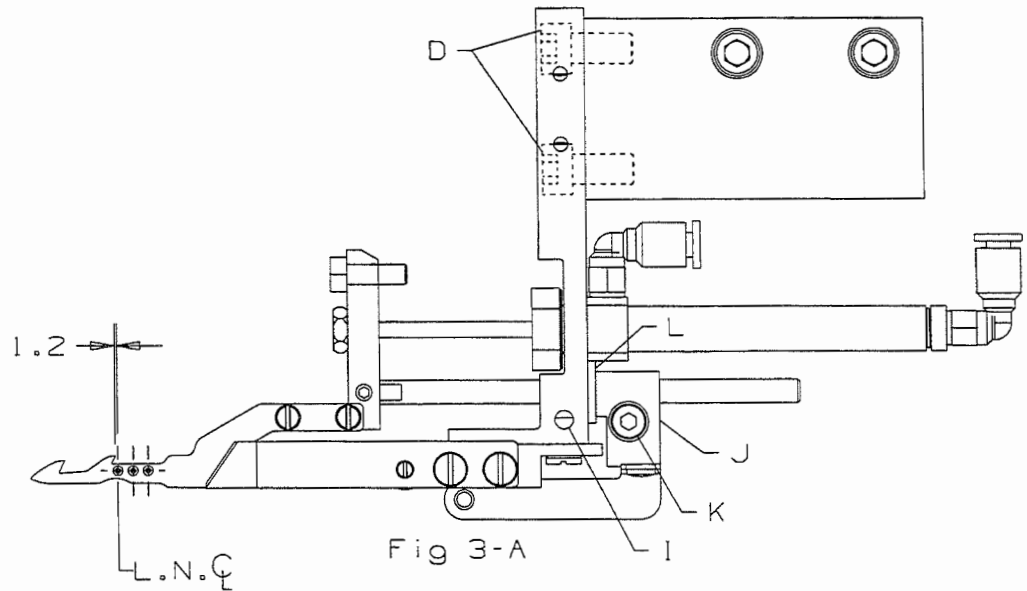

Fig 2-A

## FABRIC THREAD TRIMMER ADJUSTMENTS

With screws (D Fig 3-A) still only snug, extend the lower knife over the looper and set the height of the knife above the looper to 0.05 to 0.1mm. Use screw (I Fig 3-A) to adjust this then tighten screws (D Fig 3-A).

Adjust the stroke of the lower knife so when fully extended the needle thread knife extends 1.2mm past the left needle,(Fig 3-A). Use binder (J Fig 3-A) to adjust this by loosening screw (K Fig 3-A) and push the binder up against washer (L Fig 3-A) and tighten screw (K Fig 3-A).



## SOLENOID/PNEUMATIC THREAD WIPER

Bracket installed at 90 angle to needles.

Wiper hook (A) must deflect needle threads to operator on downstroke, (Fig. 1). Also the catch of the hook must pass the left needle by 3.0mm (1/8").

On return, wiper hook must catch all needle threads (Fig. 2) and draw them into leaf spring (B) to be clamped.

Wiper hook (A) and leaf spring (B) should be flush at point (C) when at rest position.

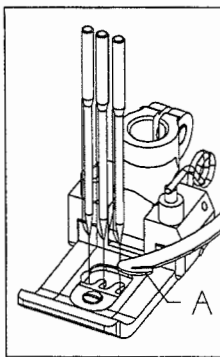
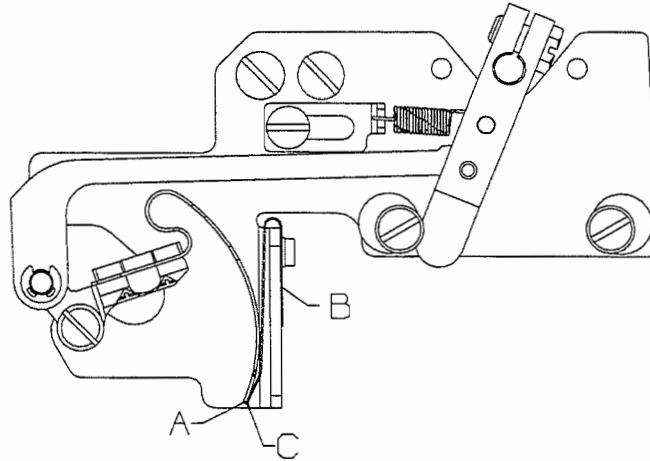

Fig.1

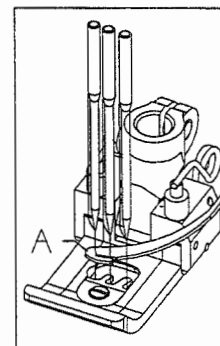
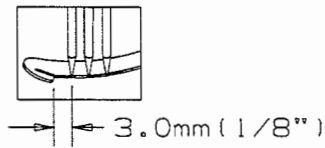

Fig.2

## ADJUSTING THREAD WIPER

Disconnect power supply for thread wiper.

Loosen screws (D). Move wiper (A) left or right as necessary.

Retighten screws (D).

Operate wiper manually to check adjustment.

Loosen screw (E), move leaf spring (B) flush with wiper (A) at point (C).

Retighten screw (E).

Reconnect power supply.

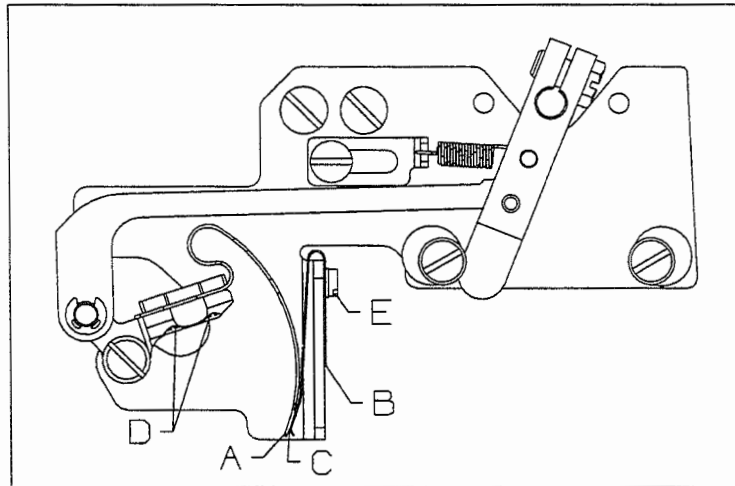

To lengthen travel past left needle.

Disconnect power supply to thread wiper.

Loosen stop screw (A) and rotate eccentric (B) so high lobe is further to left. Retighten stop screw (A).

To move wiper higher in leaf spring.

Loosen screw (C) and rotate eccentric (D) so high lobe is further to the right. Tighten stop screw (C).

Reconnect power supply.

NOTE: Recheck leaf spring setting to wiper.

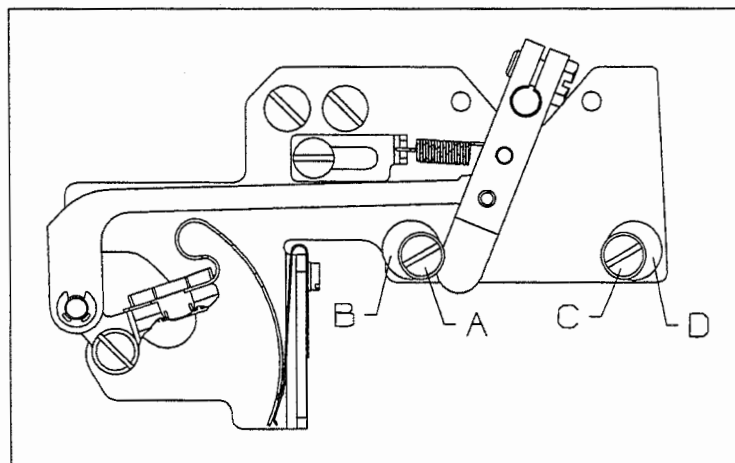



# PNEUMATIC COVER THREAD TRIMMER

The following adjustments are made with the needles at top dead center.

Set the pressure of knife (A, Fig. 1) to the minimum and still cut the spreader thread.

The trimmer activates so the hook of the knife (A, Fig. 1) picks up the spreader thread from the underside where the thread goes from the spreader to the switch.

The bottom of the moving knife should be 2mm above the presser foot when the moving knife is extended, (Fig. 1).

The clearance of the knife tip (A, Fig. 1) should be 0.4 to 0.8mm from the left needle (B, Fig. 2) and 0.2 to 0.4mm from the spreader (C, Fig. 3). the angle should be set to pick up the spreader thread.

Tighten the set screw (D, Fig. 4) in the assembly holder and also tighten the set screw (E, Fig. 4) in the collar with the collar against the holder.

The collar screw should not be removed once the trimmer is adjusted. The collar will hold the adjusted position of the trimmer if it should be removed from the holder.

NOTE: Adjust the presser foot delay so it does not interfere with the trimmer.

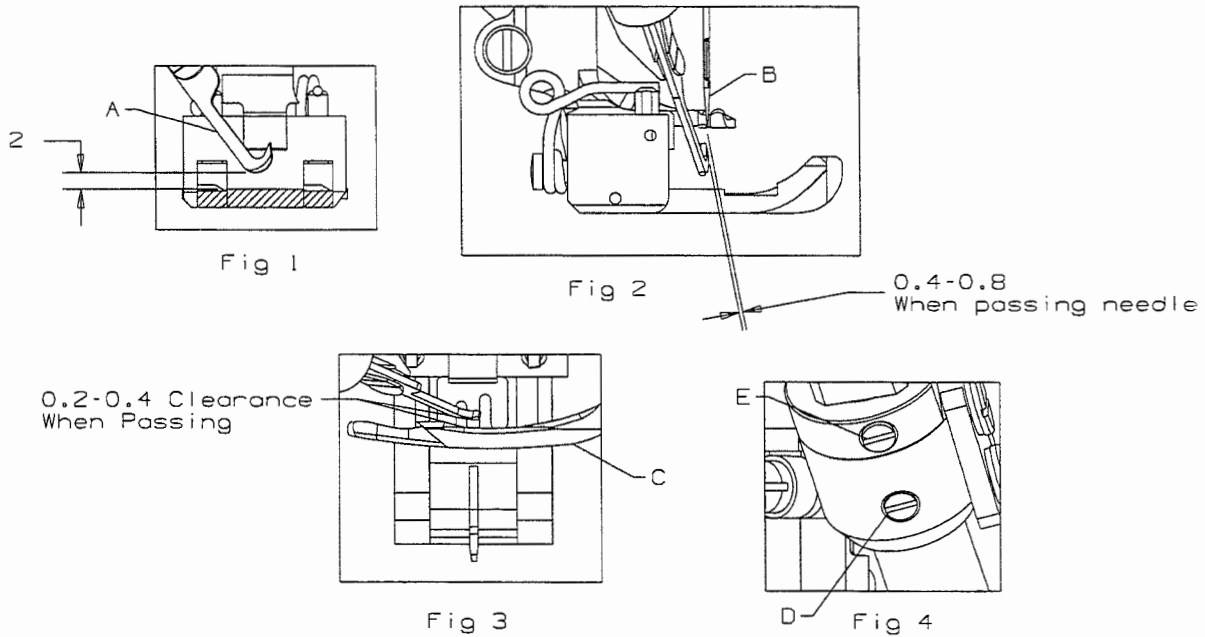

## AIR FLOW

1. Turn needle valve (A) clockwise to decrease air flow.
2. Turn needle valve (A) counterclockwise to increase air flow.

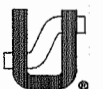
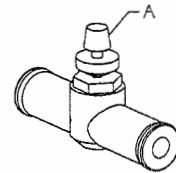

## TENSION RELEASE (UNDERBED THREAD TRIMMER)

Set separators (C, Fig. 9) as close to tension discs (D) without touching them.

Tension discs (D) must open as soon as cutting process begins.

Tension disc separators (C) should move freely between tension discs (D) without binding.

Thread trimmer and tension release assemblies are linked together.

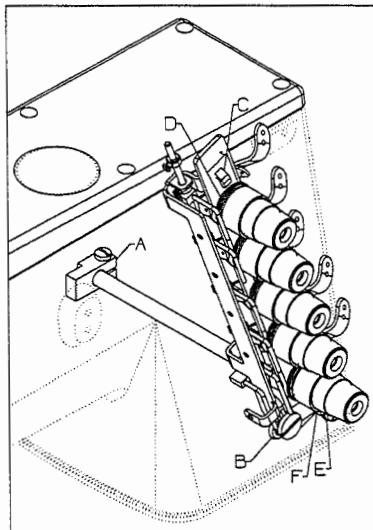

FIG 9

Loosen screw (E).

Turn eccentric (F), located behind screw (E) to set tension release lever (B) as required.

Retighten screw (E).

After adjustment there should be no binding at any point.

Adjust the tension release lever (A, fig. 9) to fully open the tension release and return without binding. The tension release is timed with the activation of the fabric thread trimmer.

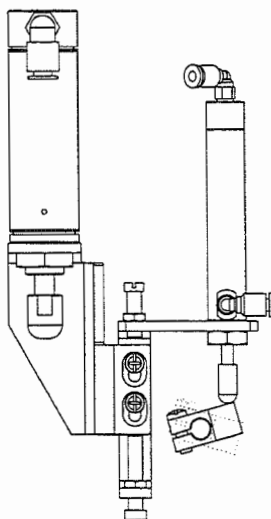

FIG 10



## THREAD PULL-OFF

Pull-off hooks (B) for needle threads, control length of needle thread tails on a garment after trimming.

Set hooks (B) to strike-off shortest tail possible and still start sewing within the first or second stitch.

Set thread pull-off hook (C), for spreader thread so that thread is clamped securely when trimmed and starts properly when the stitch is first started.

Set hook (D), for the looper thread so that the thread is clamped securely when trimmed.

NOTE: Moving strike-off hooks down strikes off more thread. Moving strike-off hooks up strikes off less thread.

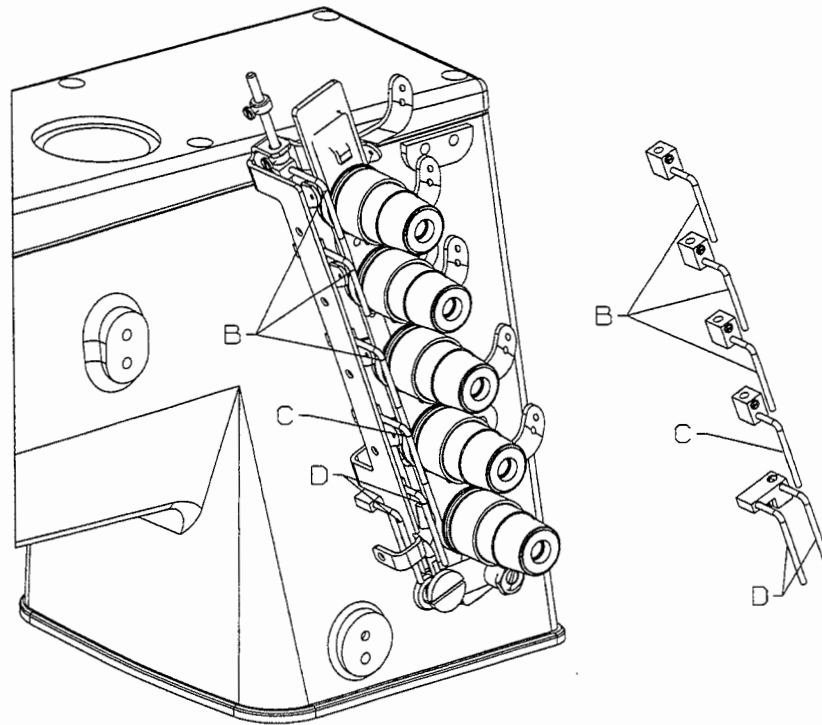
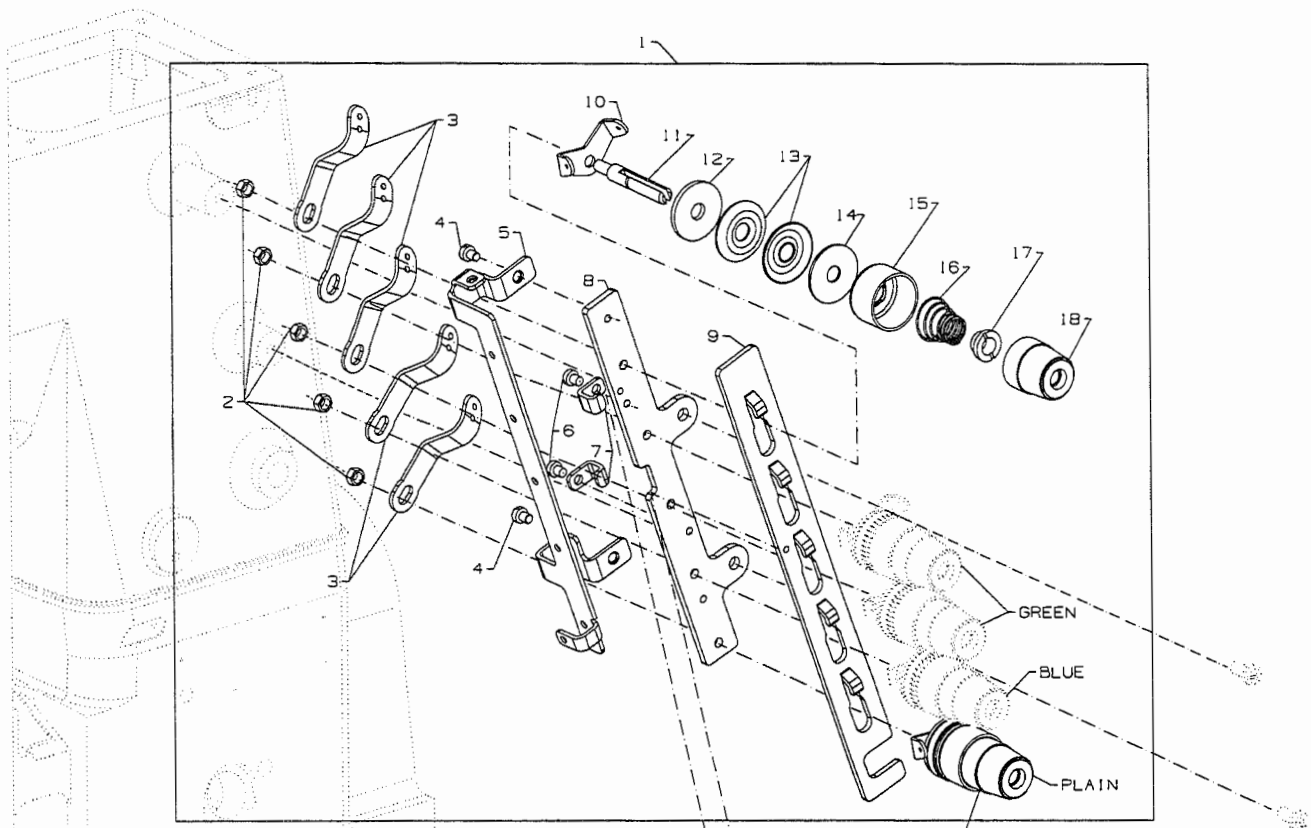

FIG11





Note: ON THIS POST ONLY  
DET'S #12 AND #14  
ARE REVERSED

GREEN AND BLUE TENSION POSTS  
REQUIRE THE USE OF 660-330.  
THE PLAIN TENSION POST REQUIRES  
THE USE OF B312035200

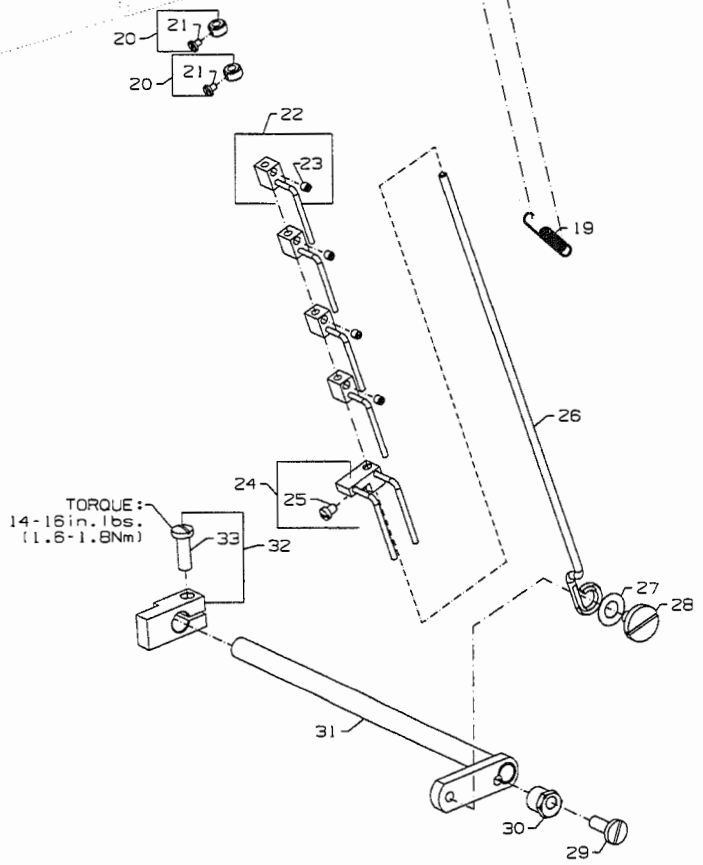

TORQUE:  
14-16 in. lbs.  
(1.6-1.8 Nm)



## THREAD TENSION

Ref. No.	Part No.	Description	Amt. Req.
1.	29477NL	5 Thread Tension Assembly .....	1
2.	NS6110420SP	Nut .....	5
3.	57865	Lead-in Thread Guide .....	5
4.	SS7090520SP	Screw .....	2
5.	50392AP	Thread Guide .....	1
6.	SS7090520SP	Screw .....	2
7.	50392AV	Guide, for tension disc separator .....	2
8.	50392X	Tension Bracket .....	1
9.	50392AR	Tension Disc Separator .....	1
10.	57892K	Thread Tension Eyelet .....	5
11.	56392G	Tension Post .....	5
12.	B3120352000	Tension Disc Felt .....	5
-	660-330	Tension Disc Felt .....	4
13.	B3126012000	Tension Disc .....	10
14.	B3120704000	Tension Disc Felt .....	1
15.	56392H	Spring Shield .....	5
16.	B3103804000	Spring, for spreader (blue) .....	1
-	11550209	Spring, for needle (green) .....	3
-	B3121804000	Spring, for looper (plain) .....	1
17.	B3112704000	Ferrule, for tension spring .....	5
18.	56392M	Knob, for spreader (blue) .....	1
-	50692G	Knob, for needle (green) .....	3
-	50392R	Knob, for looper (plain) .....	1
19.	96711	Extension Spring .....	1
20.	50368AP	Stop Collar .....	2
21.	73A	Screw .....	2
22.	50358Y	Thread Pull-off Hook .....	4
23.	28C	Screw .....	4
24.	A9858	Thread Pull-off Hook .....	1
25.	77A	Screw .....	1
26.	50392AS	Puller Rod, for thread puller .....	1
27.	50374A	Washer .....	1
28.	99296	Shoulder Screw .....	1
29.	22757	Screw .....	1
30.	G51346KA	Tension Release Eccentric .....	1
31.	50392AN	Tension Release Assembly .....	1
32.	50392BF	Tension Release Lever .....	1
33.	SS7121410TP		1



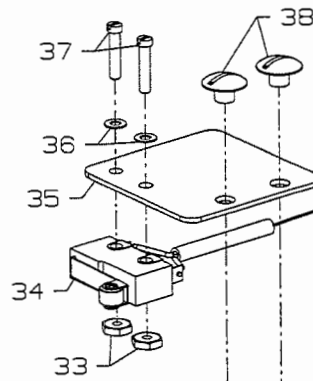

**CAUTION**  
 REFER TO THE MOTOR  
 MANUFACTURERS MANUAL FOR  
 THE PROPER CONNECTION OF THE  
 SAFETY SWITCH.

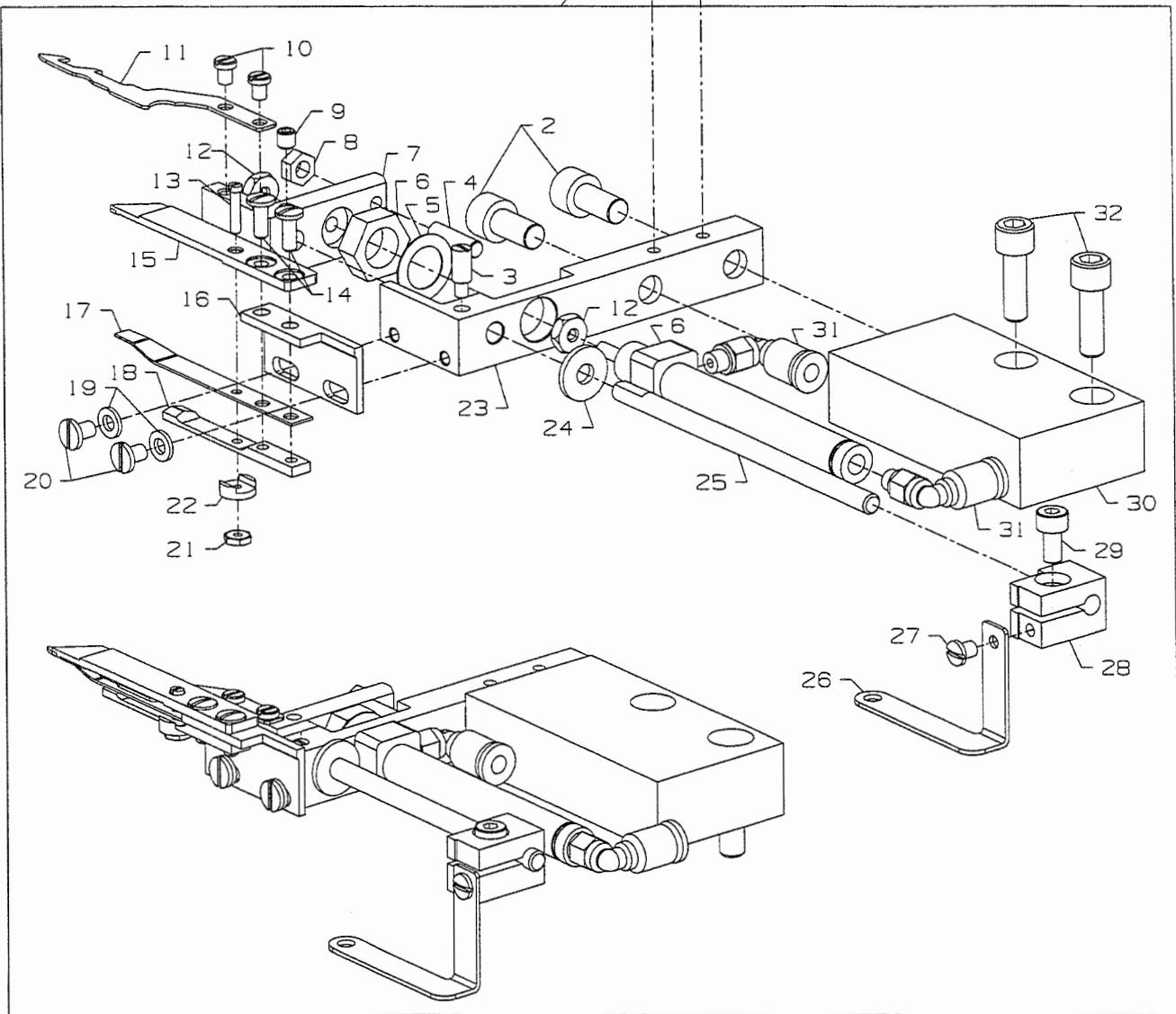

## FABRIC THREAD TRIMMER ASSEMBLY

Ref. No.	Part No.	Description	Amt. Req.
1.	29941AK	Fabric Thread Trimmer Assembly .....	1
2.	SM6061202TP	Screw .....	2
3.	SS8111251SP	Screw .....	1
4.	SM8041552TP	Screw .....	1
5.	97211	Washer .....	1
6.	671A364	Air Cylinder .....	1
7.	50367Y	Lever .....	1
8.	NM6040000SN	Nut .....	1
9.	SM8040402TP	Screw .....	1
10.	SS6080410SP	Screw .....	2
11.	50349E	Lower Knife.....	1
12.	50387A	Nut .....	2
13.	22738D	Screw .....	1
14.	22804	Screw .....	2
15.	50370K	Upper Knife .....	1
16.	50363	Bracket .....	1
17.	C50063B	Spring .....	1
18.	C50063	Arm Bracket .....	1
19.	WP0371026SD	Washer .....	2
20.	SS6090520SP	Screw .....	2
21.	60078Z	Lock Nut .....	1
22.	C50063P	Nut .....	1
23.	50383AV	Bracket .....	1
24.	50386K	Washer .....	1
25.	50322BE	Shaft .....	1
26.	50368AS	Eyelet .....	1
27.	SS7090530SP	Screw .....	1
28.	50333M	Binder .....	1
29.	SM6040802TP	Screw .....	1
30.	50362K	Base Plate .....	1
31.	671F82F	Elbow 10-32 5/32 .....	2
32.	99371E	Screw .....	2
33.	60078Z	Nut For 22738D .....	2
34.	670B352	Micro Switch Assembly .....	1
35.	50383AU	Bracket .....	1
36.	96151	Washer For 22738D .....	2
37.	22738D	Screw To Attach Sensor .....	2
38.	SS3090410SP	Screw .....	2
*39.	29476VT	Cable Assembly .....	1

\*NOTE: Item 39 not shown in exploded view



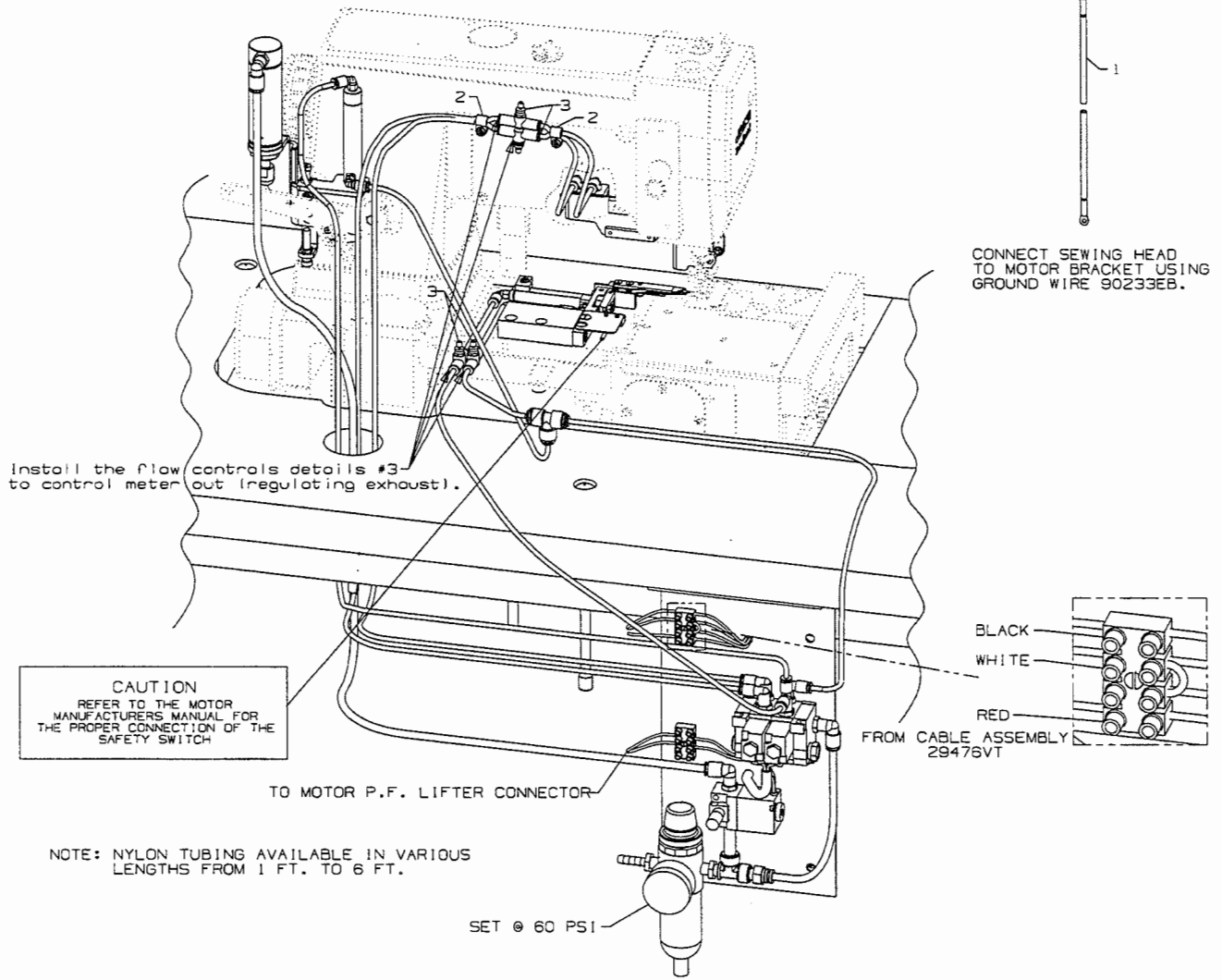



MISCELLANEOUS PARTS  
UT12AFS3

Ref. No.	Part No.	Description	Amt. Req.
1.	90233EB	Ground Wire .....	1
2.	998-358E	Cable Clamp .....	2
3.	671-168	Needle Valve .....	4



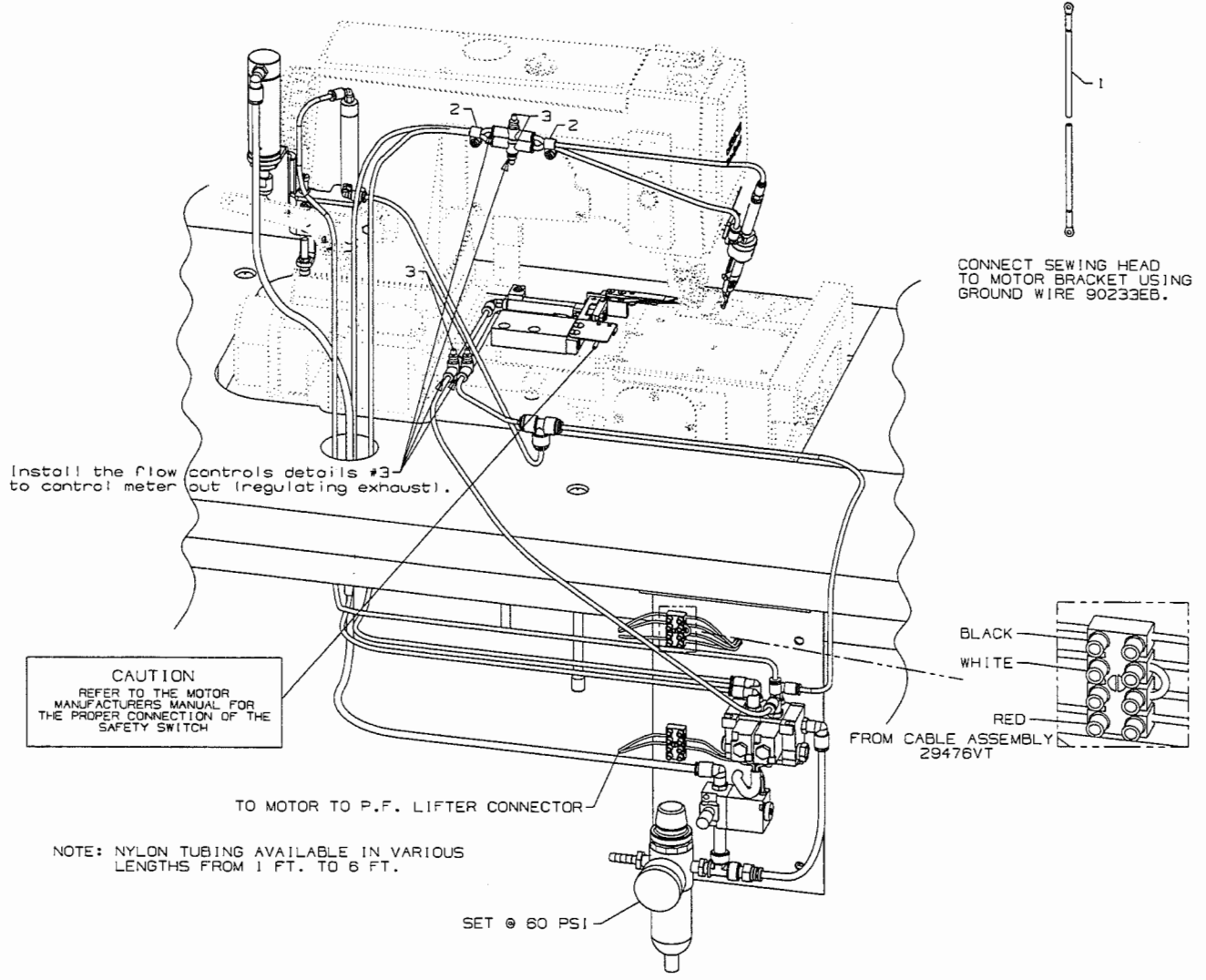

Install the flow controls details #3 to control meter out (regulating exhaust).

**CAUTION**  
 REFER TO THE MOTOR  
 MANUFACTURERS MANUAL FOR  
 THE PROPER CONNECTION OF THE  
 SAFETY SWITCH

TO MOTOR TO P.F. LIFTER CONNECTOR

NOTE: NYLON TUBING AVAILABLE IN VARIOUS  
 LENGTHS FROM 1 FT. TO 6 FT.

SET @ 60 PSI

CONNECT SEWING HEAD  
 TO MOTOR BRACKET USING  
 GROUND WIRE 90233EB.

BLACK  
 WHITE  
 RED  
 FROM CABLE ASSEMBLY  
 29476VT



MISCELLANEOUS PARTS  
UT13AFS3

Ref. No.	Part No.	Description	Amt. Req.
1.	90233EB	Ground Wire .....	1
2.	998-358E	Cable Clamp .....	2
3.	671-168	Needle Valve .....	4



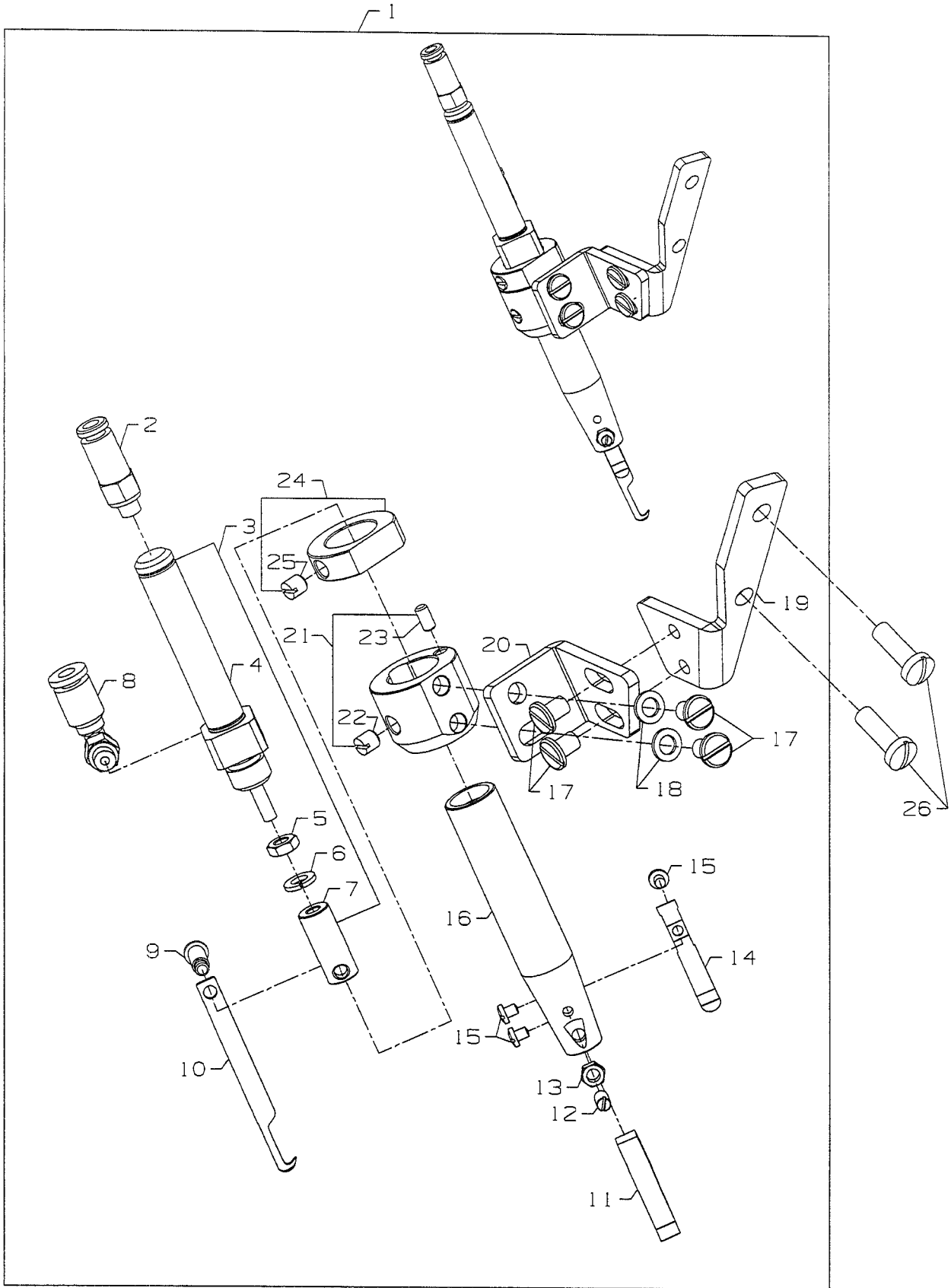

## PNEUMATIC SPREADER THREAD TRIMMER ASSEMBLY

Ref. No.	Part No.	Description	Amt. Req.
1.	29980LD	Pneumatic Spreader Thread Trimmer Assembly .....	1
2.	671F82G	Male Connector .....	1
3.	29105BP	Knife Holder Assmebly .....	1
4.	671A363	Air Cylinder .....	1
5.	660-1105	Nut .....	1
6.	WS0410002KP	Washer .....	1
7.	50372D	Moving Knife Holder .....	1
8.	671F82F	Male Elbow .....	1
9.	22731	Screw .....	1
10.	50370H	Moving Knife .....	1
11.	50349F	Lower Knife .....	1
12.	SS8080610SP	Screw .....	1
13.	NS6080210SP	Nut .....	1
14.	50332AG	Spring .....	1
15.	SS7060310SP	Screw .....	3
16.	50372C	Knife Holder .....	1
17.	SS6110610TP	Screw .....	4
18.	WP0450846SP	Washer .....	2
19.	50383AT	Bracket .....	1
20.	50383AS	Bracket .....	1
21.	50333L	Collagr, guide .....	1
22.	SS8110520TP	Screw .....	1
23.	PH0300062C0	Pin .....	1
24.	50333K	Collar .....	1
25.	SS8110520TP	Screw .....	1
26.	SS4120915SP	Mounting Screws .....	2



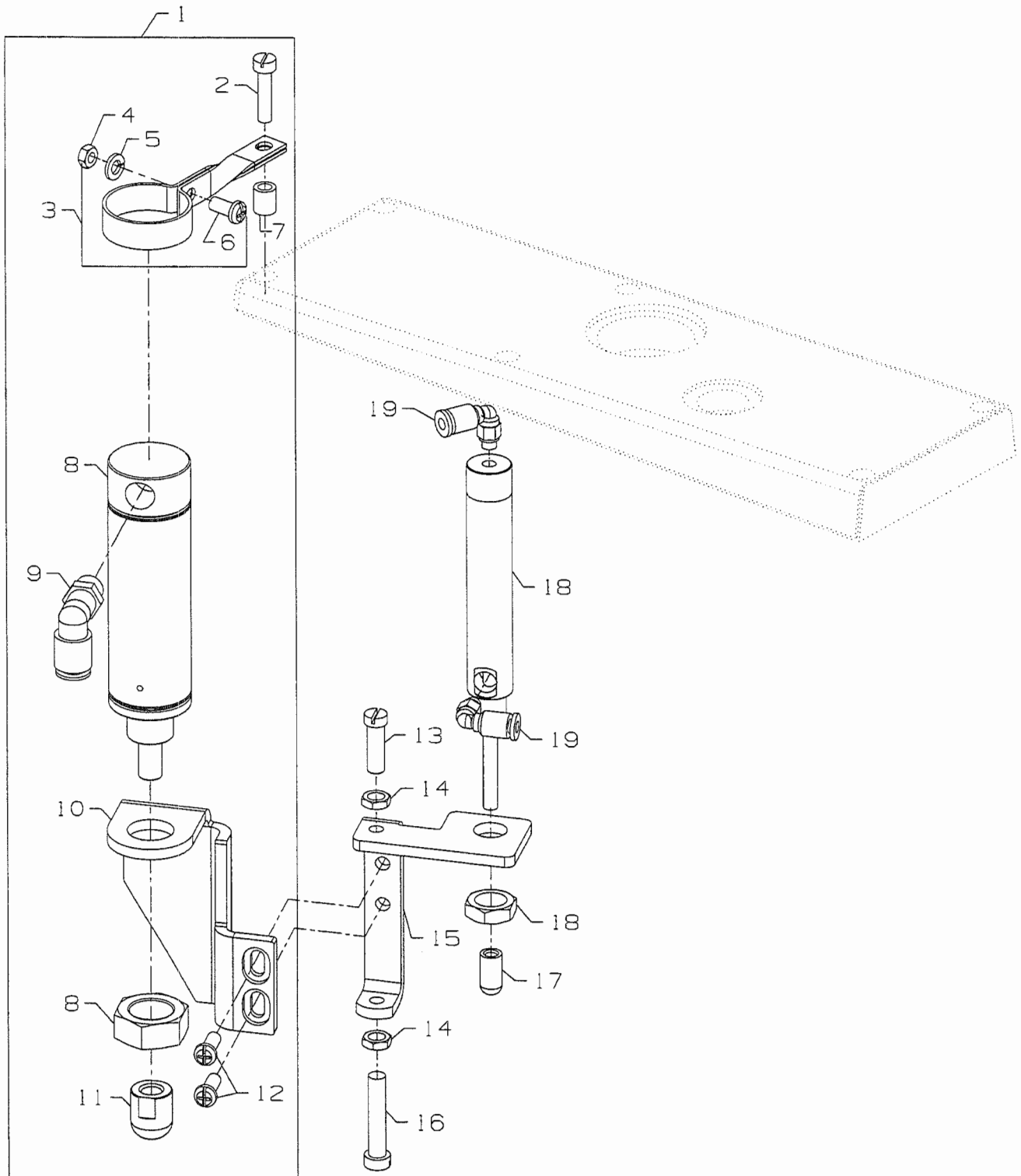

## PRESSER FOOT LIFTER ASSEMBLY

Ref. No.	Part No.	Description	Amt. Req.
1.	29480AXJ	Presser Foot Lifter Assembly .....	1
2.	SS6122030SP	Screw .....	1
3.	50383AR	Cylinder Support Bracket .....	1
4.	NS6120310SP	Nut .....	1
5.	WS0510002KP	Washer .....	1
6.	SS4121015SP	Screw .....	1
7.	50374K	Spacer .....	1
8.	671A360	Air Cylinder .....	1
9.	671F81C	Fitting .....	1
10.	50383AF	Bracket .....	1
11.	660-1099	Air Cylinder Cap .....	1
12.	SS7121410TP	Screw .....	2
13.	SS6151920SP	Screw .....	1
14.	NS6150310SP	Locking Nut .....	2
15.	50383AG	Bracket .....	1
16.	SS6153040SP	Screw .....	1
17.	671G21	Cylinder Tip, for positioning bracket .....	1
18.	671A365	Air Cylinder, for positioning bracket .....	1
19.	671F82F	Flow Control, for positioning bracket .....	2



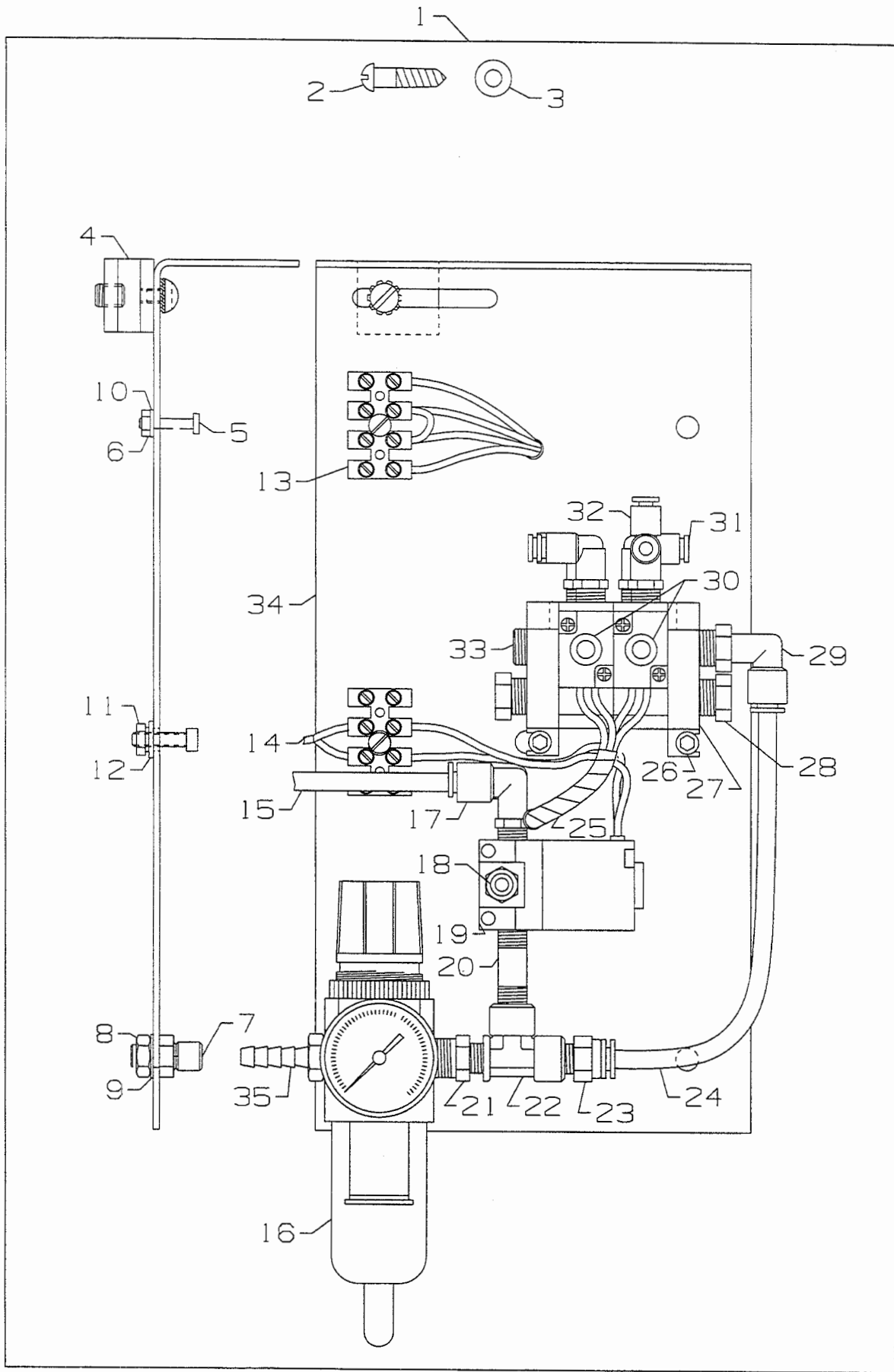



## PNEUMATIC CONTROL ASSEMBLY

Ref. No.	Part No.	Description	Amt. Req.
1.	29480AWM	Pneumatic Control Assembly .....	1
2.	SC330	Wood Screw .....	2
3.	RM3293-6	Washer .....	4
4.	661-3	Mounting Clip .....	2
5.	RM2805-3	Screw .....	2
6.	660-478A	Nut .....	2
7.	671C16	Stud .....	1
8.	11635B	Nut .....	1
9.	652B20	Washer .....	1
10.	RM3293-7	Washer .....	2
11.	660-602	Nut .....	2
12.	RM3993-3	Lock Washer .....	2
13.	670-G36	Terminal Block .....	2
14.	670E1405	Wiring Harness .....	1
15.	RM2997D	Tubing (1/4" x 15') .....	1
16.	671D42	Regulator .....	1
17.	671F81C	Elbow Fitting .....	1
18.	660-403	Muffler .....	1
19.	671-50	Air Valve .....	1
20.	RM2948-1	Pipe Nipple .....	1
21.	671F6	Bushing .....	1
22.	RM2850D	"T" Fitting .....	1
23.	671F81D	Straight Fitting .....	1
24.	RM2997D	Tubing (1/4" x 7 1/4") .....	1
25.	RM3832-2	Spiral Wrap (1') .....	1
26.	22652B12	Socket Head Screw .....	2
27.	671-104A	Valve Bracket .....	1
28.	660-763	Muffler .....	2
29.	671F81A	Elbow Fitting .....	1
30.	671-103A	Valve Insert .....	2
31.	671F82C	Elbow Fitting .....	3
32.	671F82E	"T" Fitting .....	1
33.	671F87	Plug .....	1
34.	35032R	Mounting Bracket .....	1
35.	671F88	Barb Fitting .....	1



NUMERICAL INDEX OF PARTS

<u>Part No.</u>	<u>Page No.</u>	<u>Part No.</u>	<u>Page No.</u>	<u>Part No.</u>	<u>Page No.</u>
11550209	13	50392X	13	B3103804000	13
11635B	25	50692G	13	B3112704000	13
22652B12	25	56392G	13	B3120352000	13
22731	21	56392H	13	B3120704000	13
22738D	15	56392M	13	B3121804000	13
22757	13	57865	13	B3126012000	13
22804	15	57892K	13	C50063	15
28C	13	60078Z	15	C50063B	15
29105BP	21	652B20	25	C50063P	15
29476VT	15	660-1099	23	G51346KA	13
29477NL	13	660-1105	21	NM6040000SN	15
29480AWM	25	660-330	13	NS6080210SP	21
29480AXJ	23	660-403	25	NS6110420SP	13
29941AK	15	660-478A	25	NS6120310SP	23
29980LD	21	660-602	25	NS6150310SP	23
35032R	25	660-763	25	PH0300062C0	21
50322BE	15	661-3	25	RM2805-3	25
50332AG	21	670-G36	25	RM2850D	25
50333K	21	670B352	15	RM2948-1	25
50333L	21	670E1405	25	RM2997D	25
50333M	15	671-103A	25	RM3293-6	25
50349E	15	671-104A	25	RM3293-7	25
50349F	21	671-168	17, 19	RM3832-2	25
50358Y	13	671-50	25	RM3993-3	25
50362K	15	671A360	23	SC330	25
50363	15	671A363	21	SM6040802TP	15
50367Y	15	671A364	15	SM6061202TP	15
50368AP	13	671A365	23	SM8040402TP	15
50368AS	15	671C16	25	SM8041552TP	15
50370H	21	671D42	25	SS3090410SP	15
50370K	15	671F6	25	SS4120915SP	21
50372C	21	671F81A	25	SS4121015SP	23
50372D	21	671F81C	23, 25	SS6080410SP	15
50374A	13	671F81D	25	SS6090520SP	15
50374K	23	671F82C	25	SS6110610TP	21
50383AF	23	671F82E	25	SS6122030SP	23
50383AG	23	671F82F	15, 21, 23	SS6151920SP	23
50383AR	23	671F82G	21	SS6153040SP	23
50383AS	21	671F87	25	SS7060310SP	21
50383AT	21	671F88	25	SS7090520SP	13
50383AU	15	671G21	23	SS7090530SP	15
50383AV	15	73A	13	SS7121410TP	13, 23
50386K	15	77A	13	SS8080610SP	21
50387A	15	90233EB	17, 19	SS8110520TP	21
50392AN	13	96151	15	SS8111251SP	15
50392AP	13	96711	13	WP0371026SD	15
50392AR	13	97211	15	WP0450846SP	21
50392AS	13	99296	13	WS0410002KP	21
50392AV	13	99371E	15	WS0510002KP	23
50392BF	13	998-358E	17, 19		
50392R	13	A9858	13		

