

SINGER
211W151

PARTS LIST
FOR
SINGER
211_w151 MACHINE

Parts marked with a diamond (♦) are furnished only when repairs are made at the factory; these (♦) parts are named at bottom of descriptive list opposite illustration.

ARM SHAFT, NEEDLE BAR AND TAKE-UP ASSEMBLY

Ref. No.	Part No.	Description
1	240139	Take-up Lever
2	267239	Hinge Stud with 235706
3	235706	Oil Packing (wick)
4	200383C	Hinge Stud Set Screw
5	202552	Connecting Link
6	202399	Driving Stud with 244071
7	244071	Oil Packing (wick)
8	264714	Connecting Stud with 200072C and 202330
9	200072C	Pinch Screw
10	202330	Oil Packing (wick)
11	267160	Oil Pad (felt) (upper)
12	267236	Oil Reservoir Oil Wick
13	267247	Arm Shaft ♦267158 with 200333C, 200347AL, 200378C, 200388C, 267221 and ♦267222
14	267221	Connecting Link Stud with 267466
15	267466	Oil Packing (wick)
16	200374AL	Set Screw
17	200388C	Set Screw
18	200333C	Position Screw
19	200378C	Position Screw Check Screw
20	267224	Friction Washer
21	244747	Arm Shaft Bushing
22	204329	Oil Pad (felt) (lower)
23	200341C	Set Screw
24	267162	Belt Pulley with 200363AL, 350492C and two 202253
25	202253	Spring Flange
26	350492C	Position Screw
27	200363AL	Set Screw
28	267161	Connection Belt (reinforced neoprene)
29	244722	Machine Pulley 244721 with 272142
30	244721	Machine Pulley (aluminum alloy casting) for "V" belt (outside diam. of belt groove 2.9 in.) (rim diam. 4 in.) (inside belt groove) with 141566C and 141567C
31	141566C	Position Screw
32	141567C	Set Screw
33	272142	Bearing (back) (double shielded bearing)
34	240020	Needle Bar with 200125ALX, 200175D and 240039
35	200125ALX	Set Screw
36	200175D	Needle Bar Thread Guide Screw
37	240039	Needle Bar Thread Guide
38	244726	Take-up Lever Guard
39	201341C	Guard Screw (3)
	♦267158	Arm Shaft
	♦267222	Needle Bar Crank

ARM SHAFT, NEEDLE BAR AND TAKE-UP ASSEMBLY

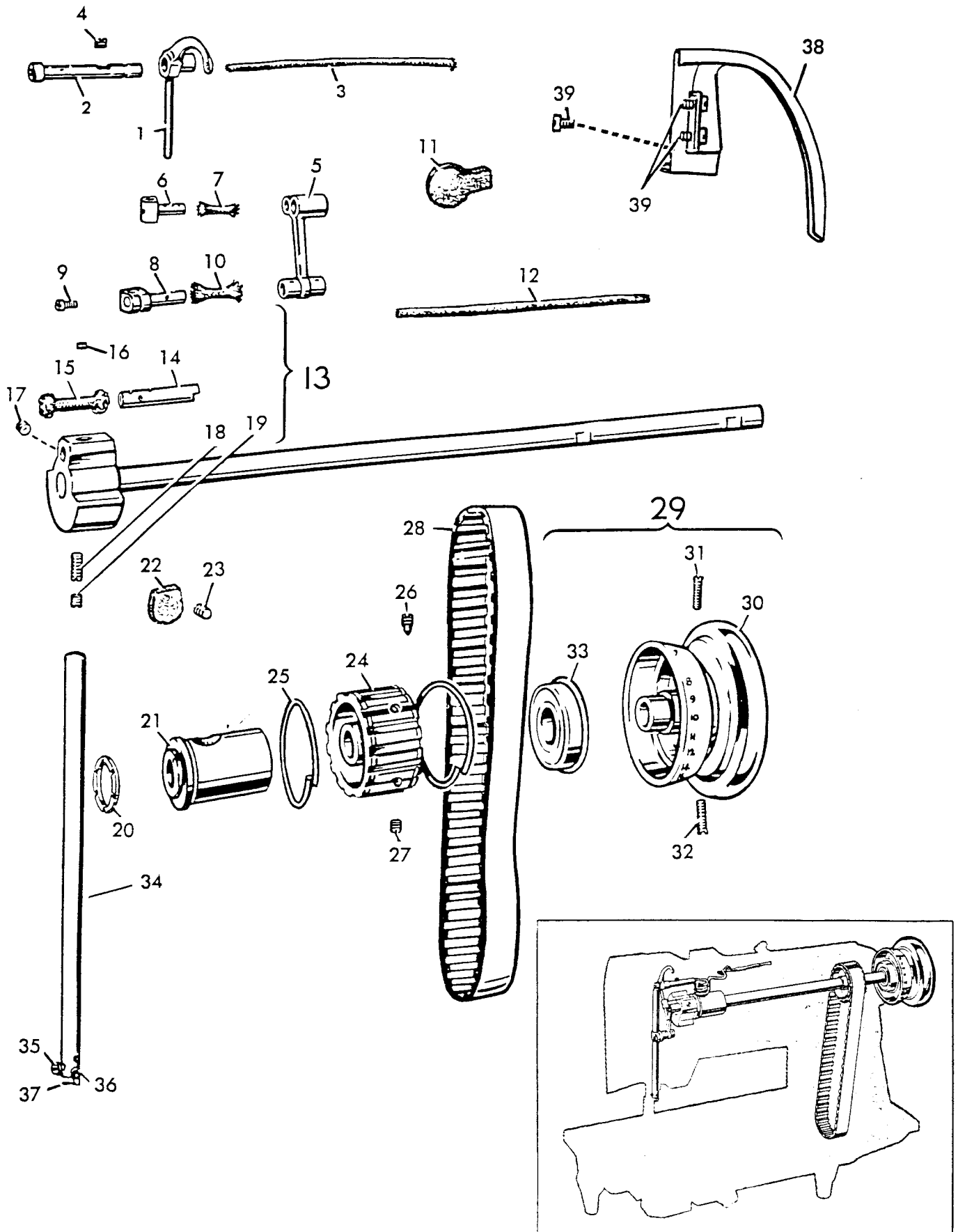

LUBRICATION DEVICE, BED SLIDES, COVERS AND MISCELLANEOUS PARTS

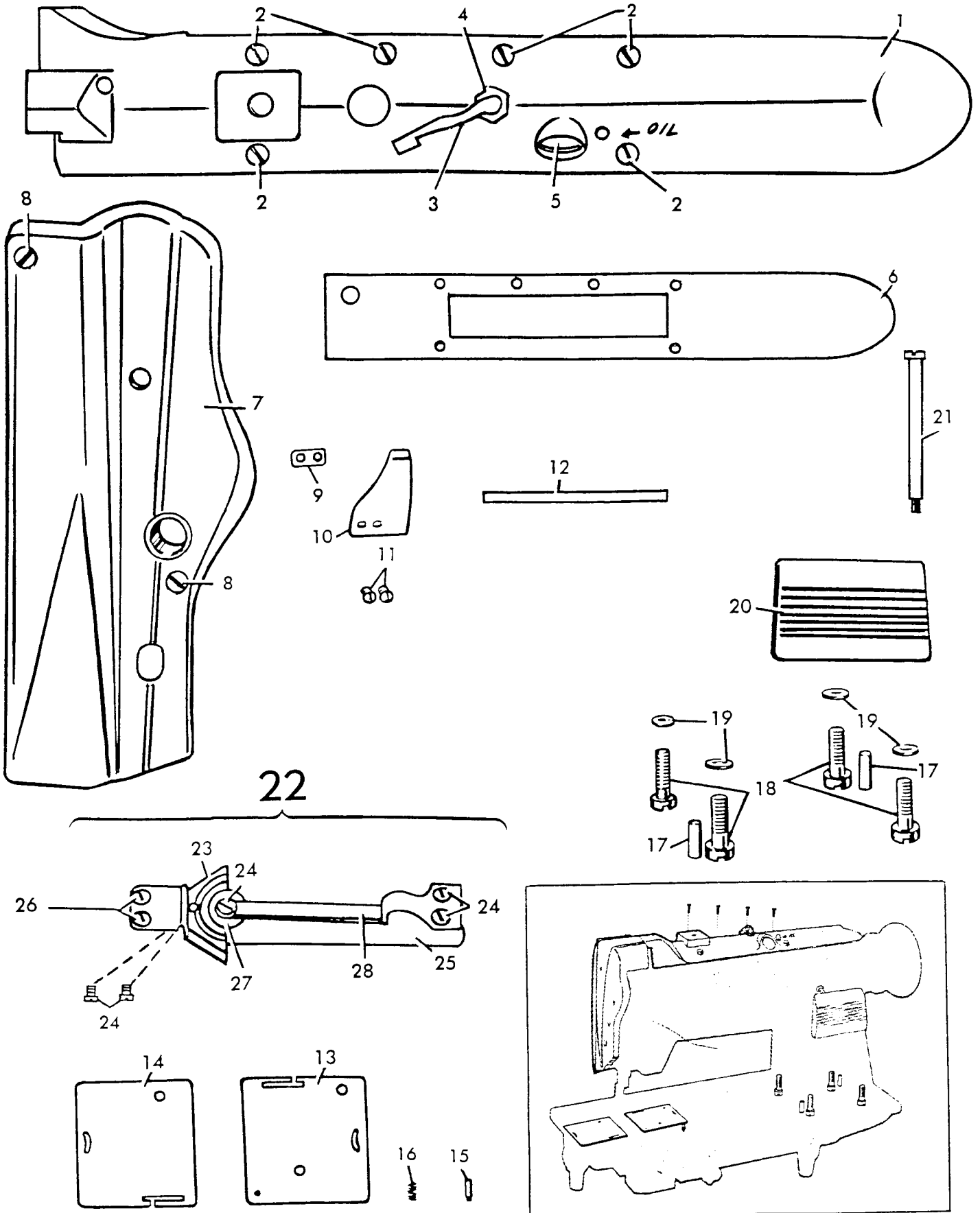

PRESSER BAR, PRESSER FOOT, PRESSER FOOT LIFTING ASSEMBLY AND THROAT PLATE

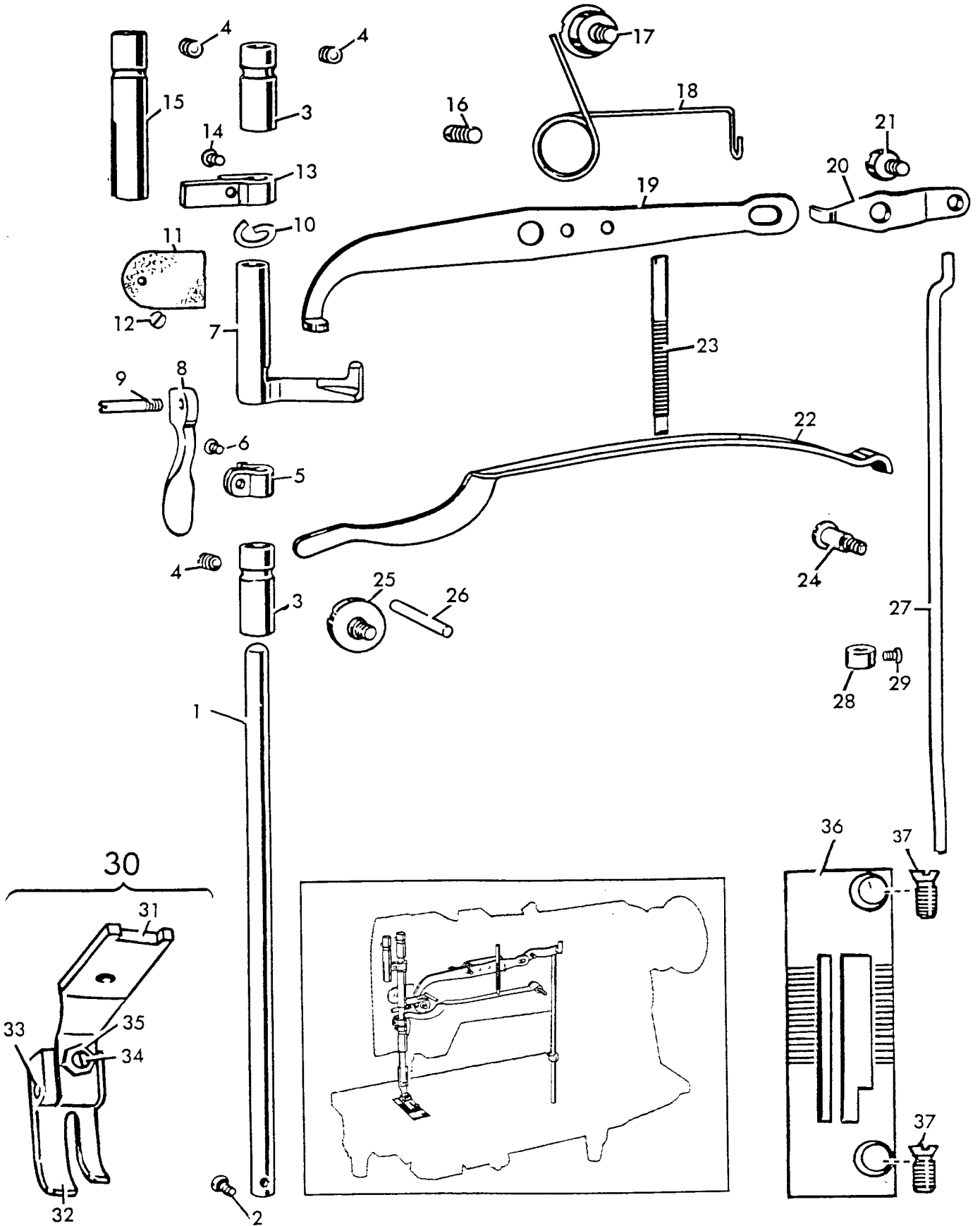

TENSION COMPLETE, THREAD GUIDES AND THREAD LUBRICATOR

1

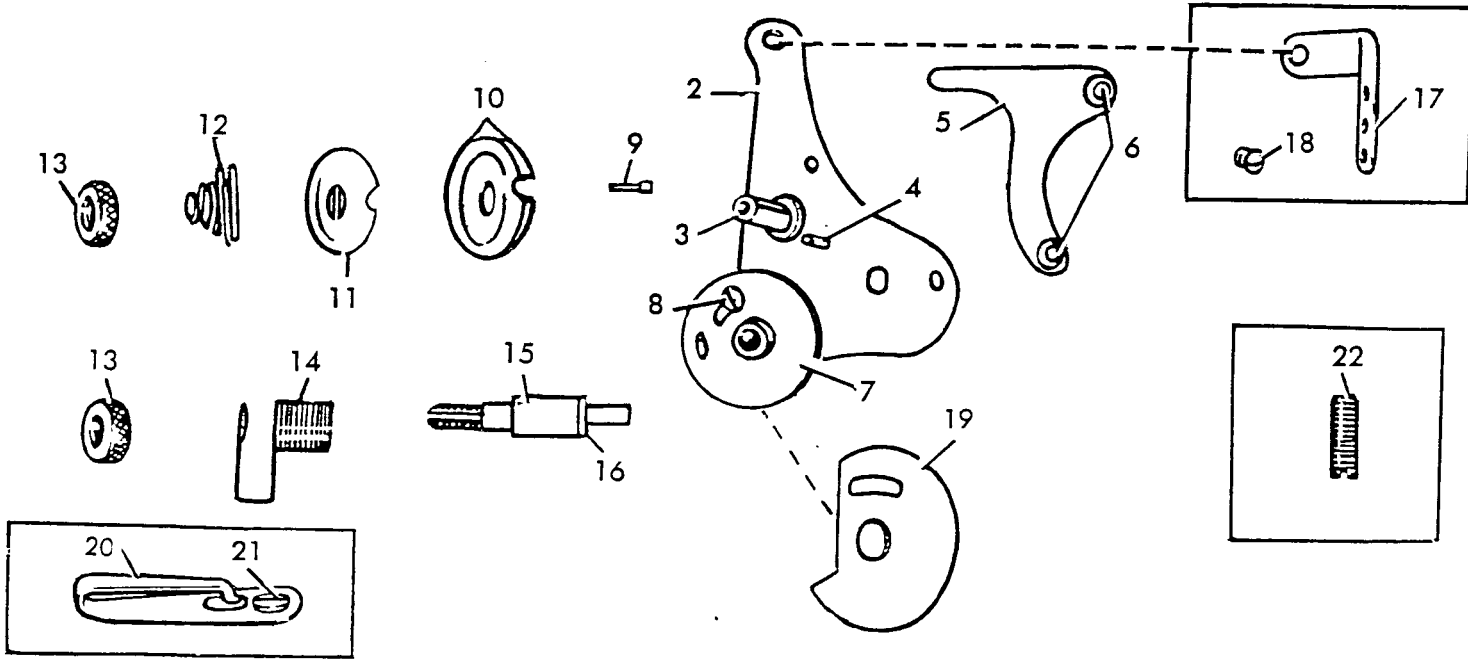

23

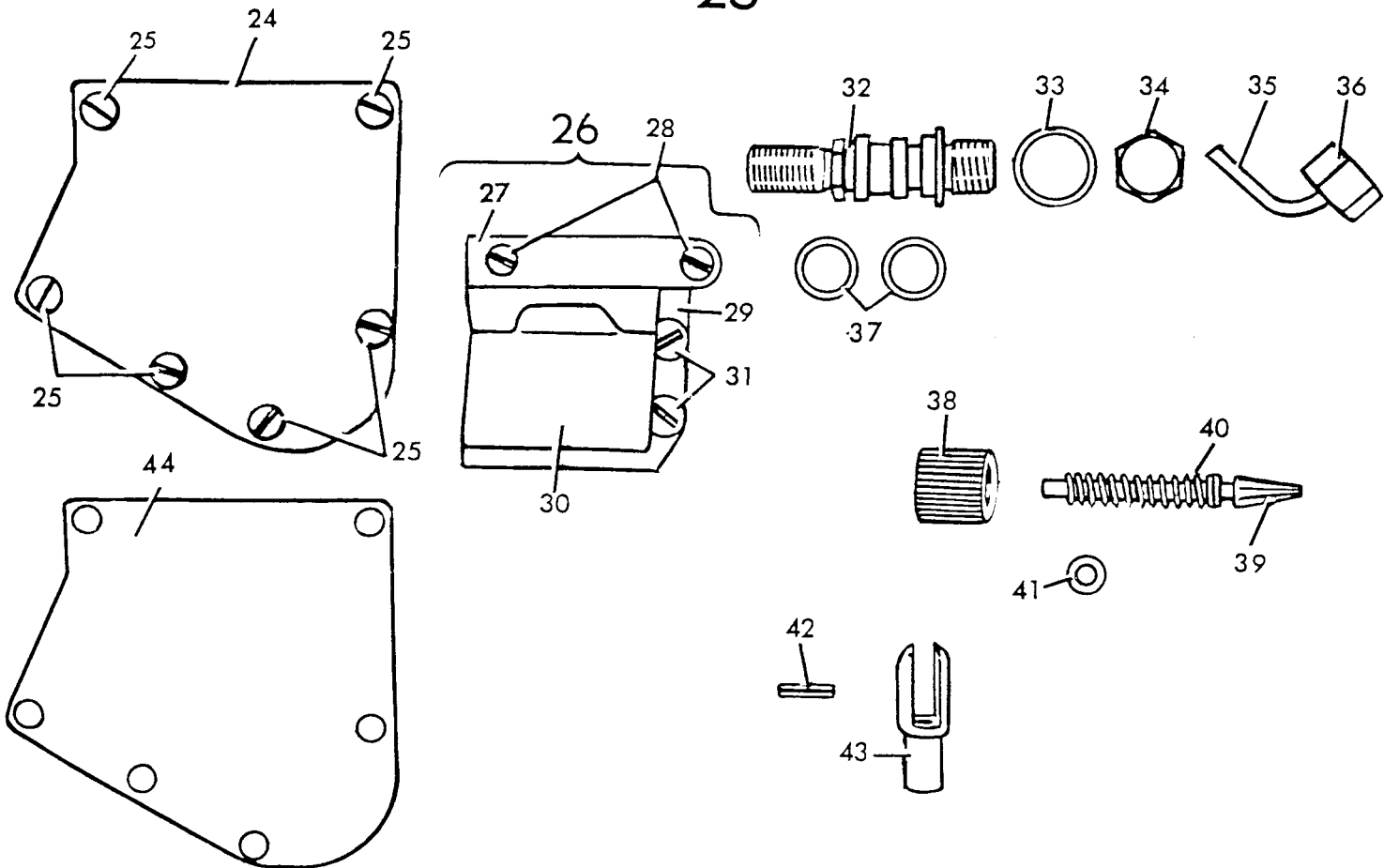

LOWER FEED ASSEMBLY WITH FEED DOG

14

13

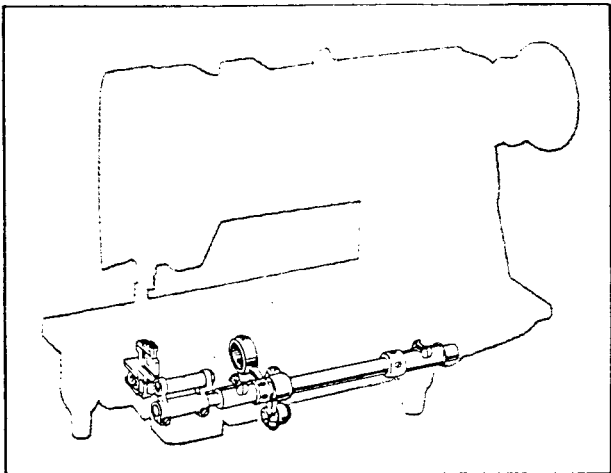
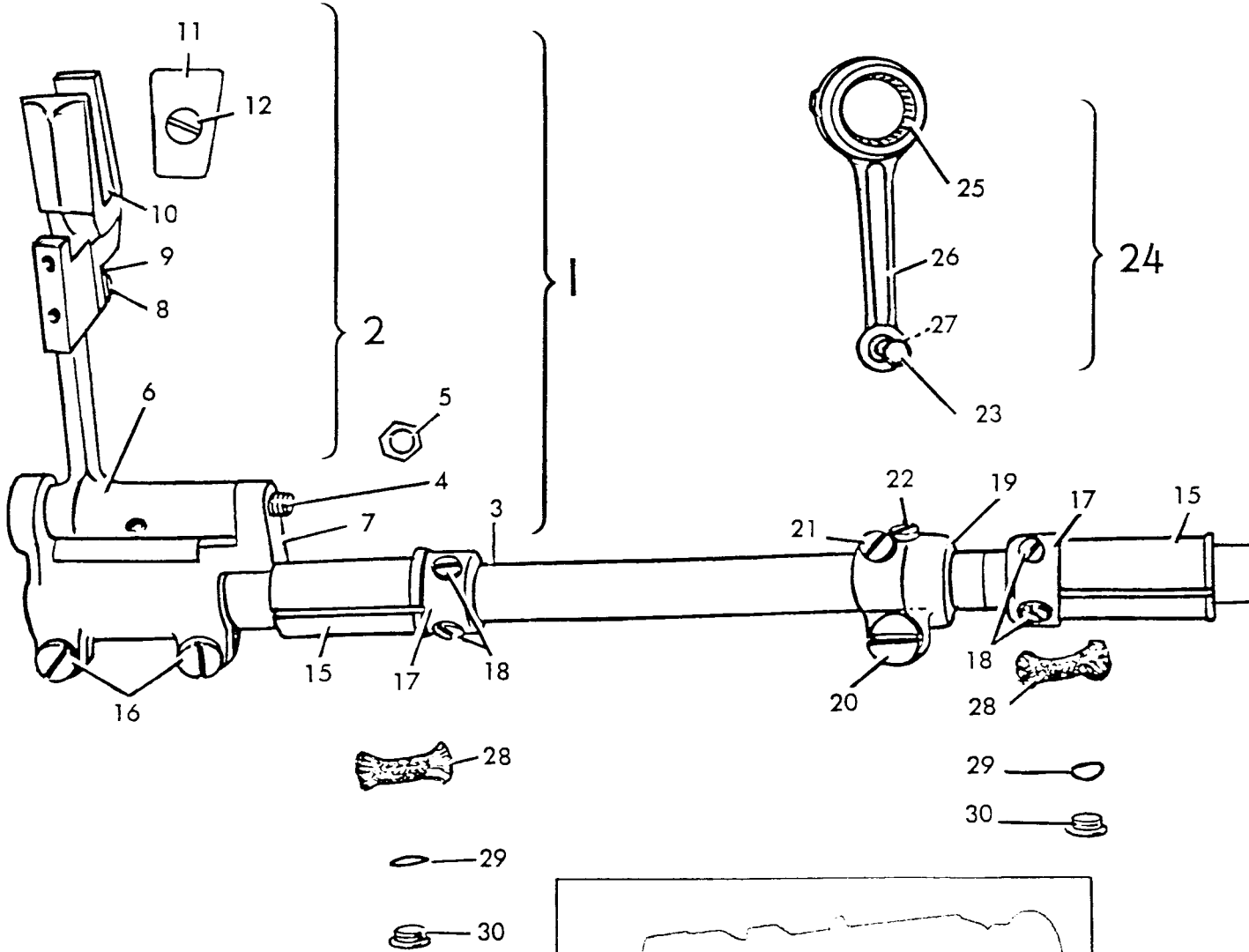

HOOK DRIVING AND FEED DRIVING ECCENTRIC ASSEMBLY WITH HOOK SADDLE BEARINGS

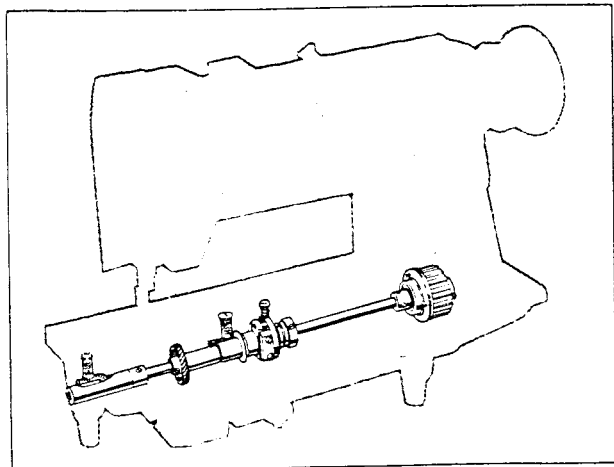
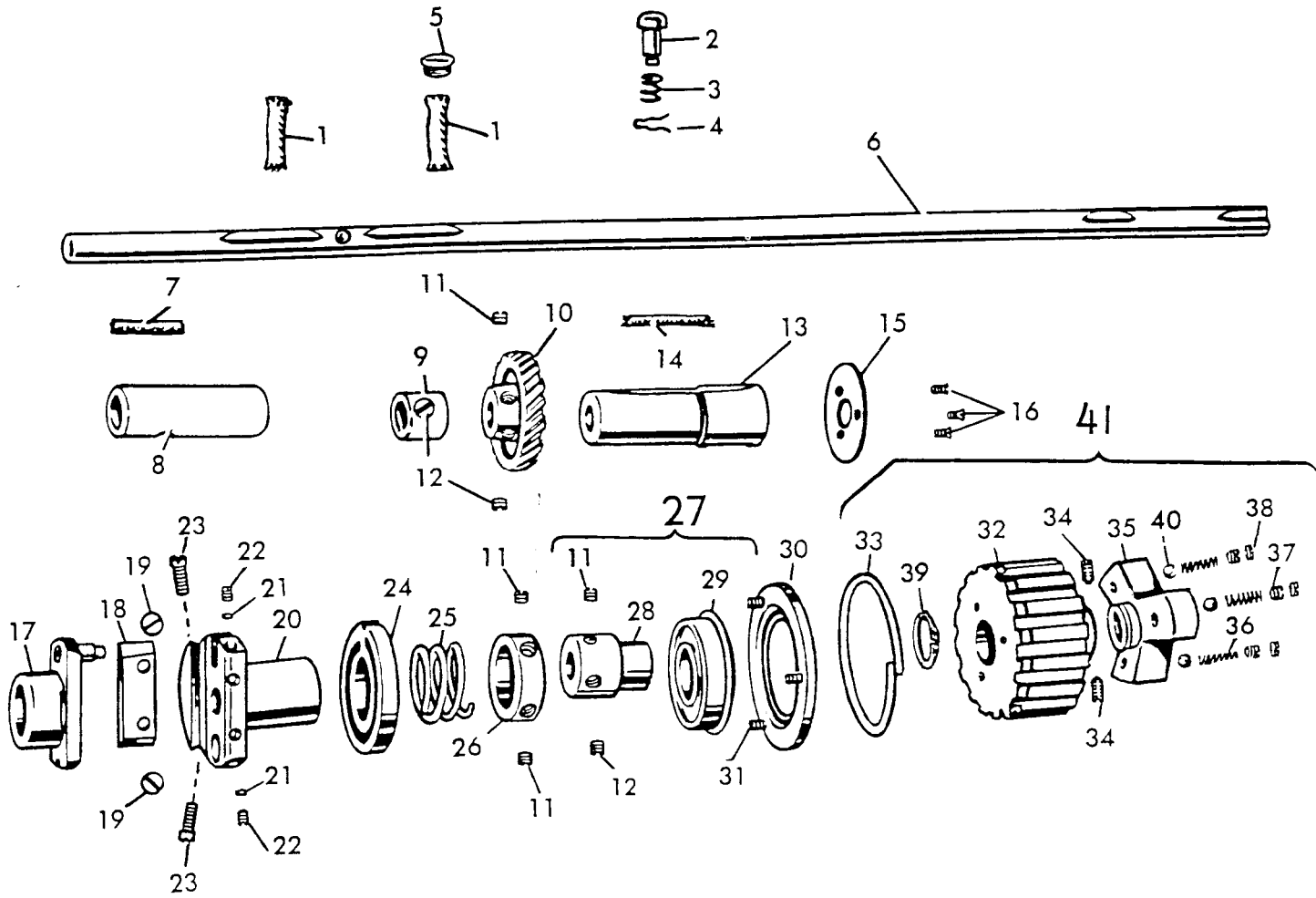

HOOK AND BOBBIN CASE WITH BOBBIN

1

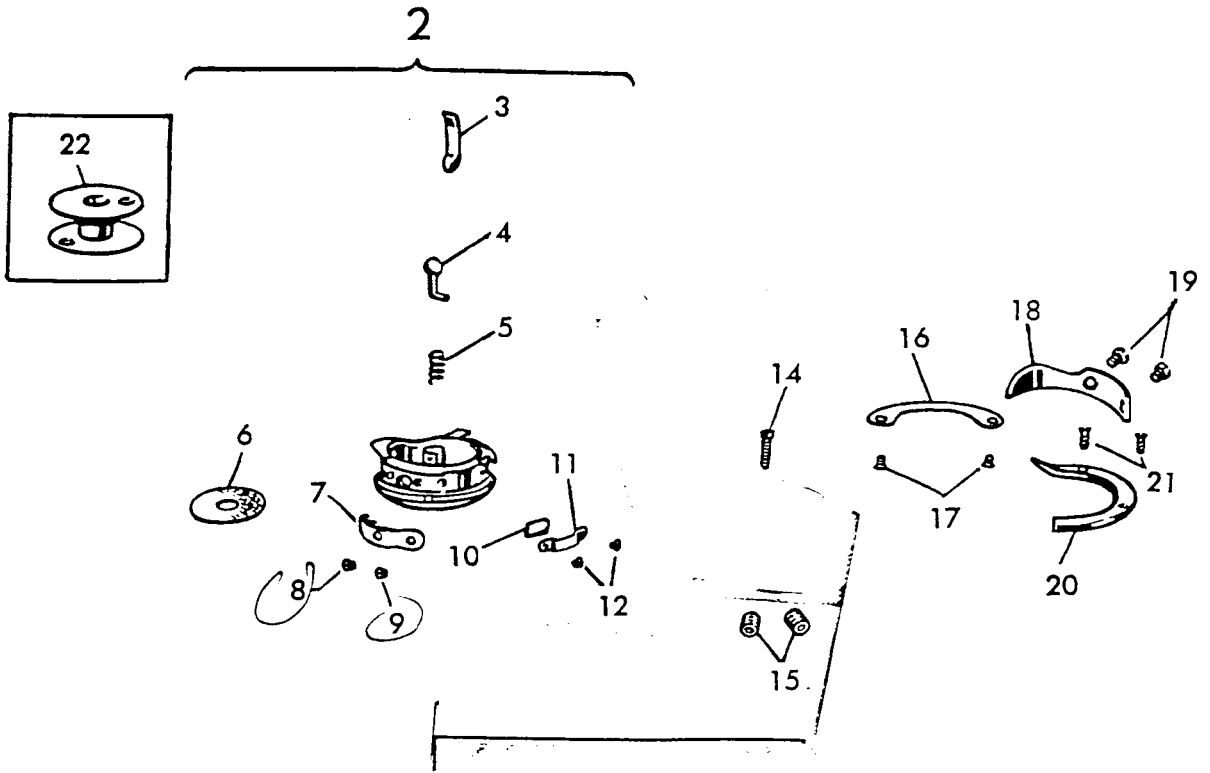

HOOK SADDLE COMPLETE

<u>Ref. No.</u>	<u>Part No.</u>	<u>Description</u>
1	244720	Hook Saddle complete, Nos. 200110D, 200374ALX, 200378C, 200388C, 244084, 244704, 244711, 267053, 267166, 267167, 267172, 267194, 267198, 267200, 267212, 267215, 267248, 267351, 267365, 267366, 350564E, two each 200089X, 200135C, 267361 and eight 200061ALX
2	244711	Hook and Bobbin Case complete
3	267053	Hook Ball Bearing
4	267361	Retainer
5	200089X	Screw
6	276061	Oil Wick Holder
7	270880	Oil Wick
8	267215	Hook Shaft with 80 and 276061
9	267172	Link
10	200135C	Cap Screw
11	244704	Cam Shaft
12	267366	Pinion (two 350595XC)
13	350595XC	Set S
14	350564E	Oil Frew
15	267167	Hinge
16	267166	Opener Crank
17	267351	Bobbin Case Opener
18	200110D	Screw
19	267248	Pinion Thrust Bearing
20	267367	Hook S
21	267194	Hook S 367, 267370 and 267371
22	267371	Cam S
23	267365	Cam S wo 350595XC
24	267370	Cam S
25	200378C	Oil Regrew
26	244084	Check
27	200185D	Oil Stop Screw
28	200374ALX	Hinge Stud Set Screw
29	200388C	Check Screw
30	267198	Oil Gauge Sleeve with 267277
31	267277	Oil Strainer
32	267212	Gasket
33	267200	Oil Reservoir
34	200061ALX	Screw
35	267140	Pinch Sleeve (upper)
36	267139	Pinch Sleeve (lower)
37	200001E	Screw
38	225585	Washer
39	200006E	Hook Saddle Screw

HOOK SADDLE COMPLETE

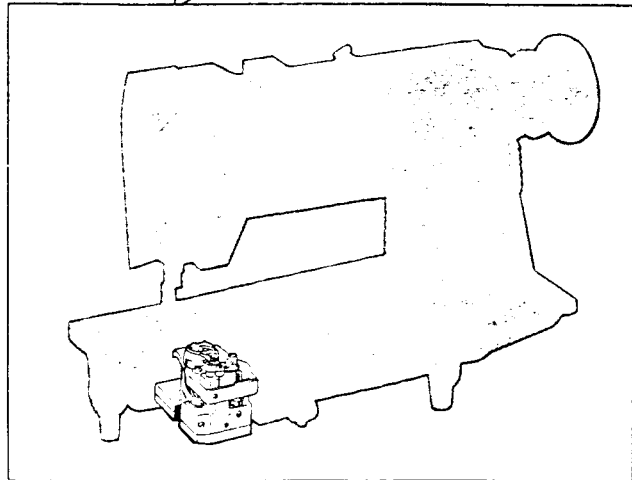
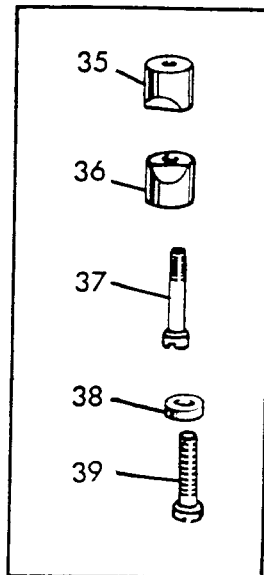
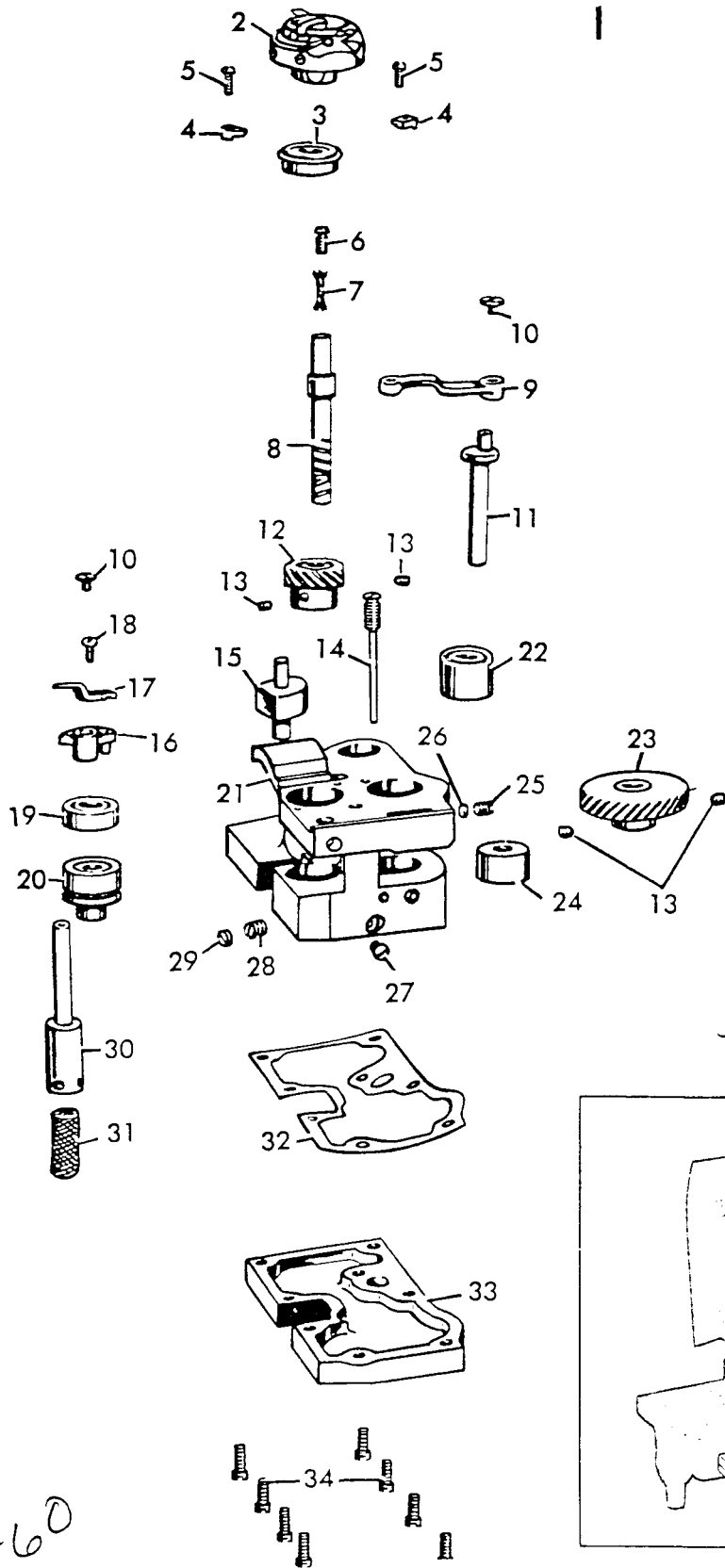

508278 - 5.10
 244710 13.30

 8.20

244720 - 108.60
 64.50

 44.10

240560

NEEDLE BAR ROCK FRAME, NEEDLE BAR ROCK FRAME
ROCK SHAFT AND LUBRICATING WICKS

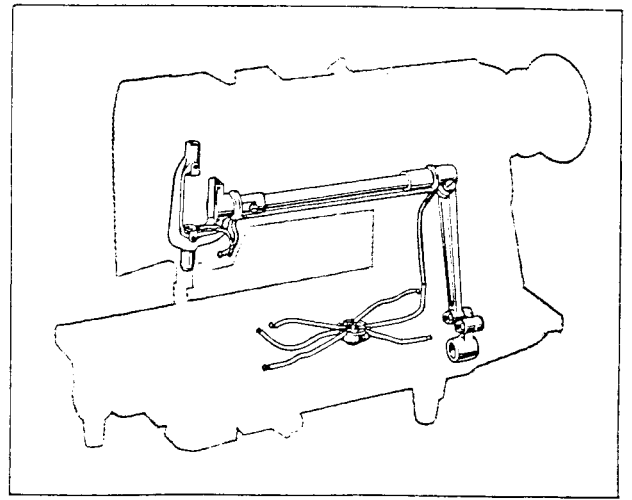
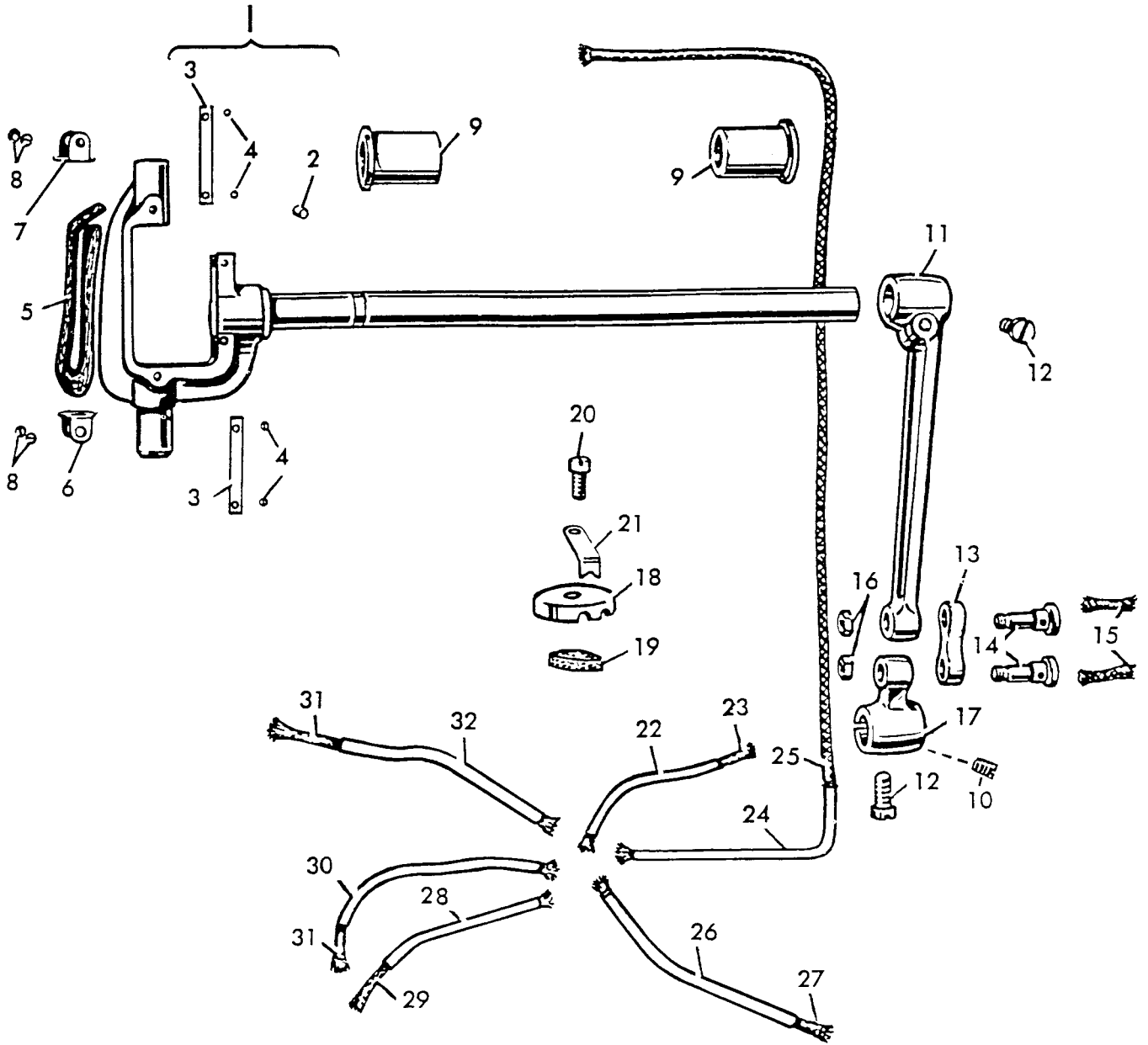

ACCESSORIES

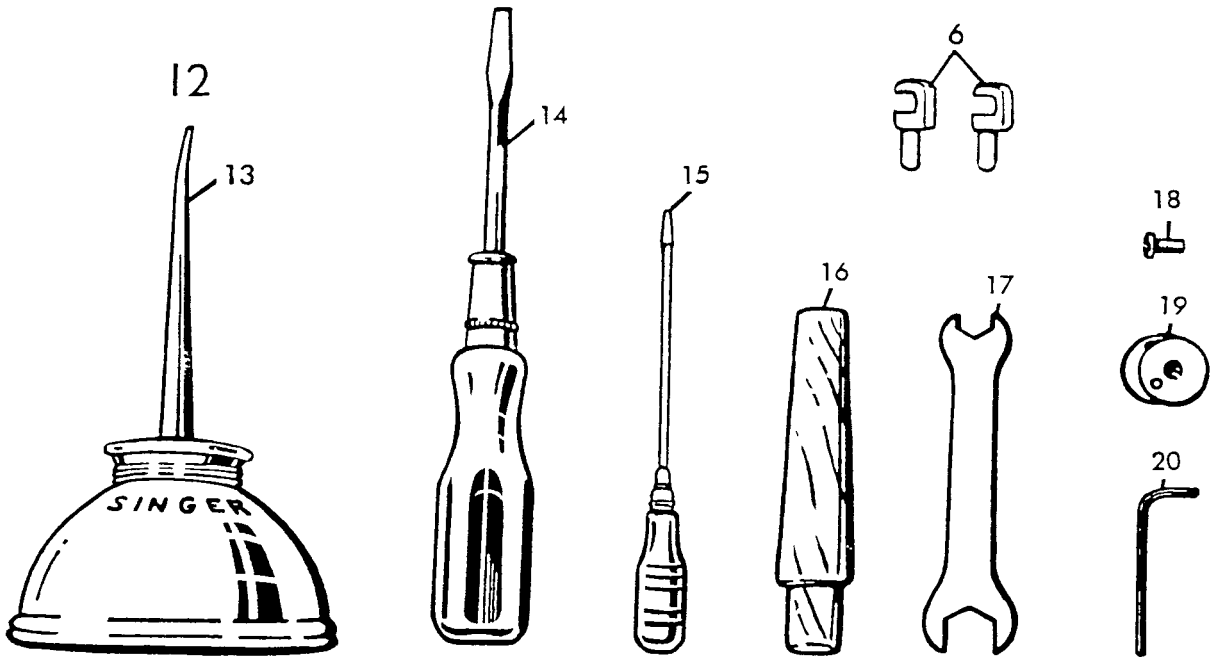
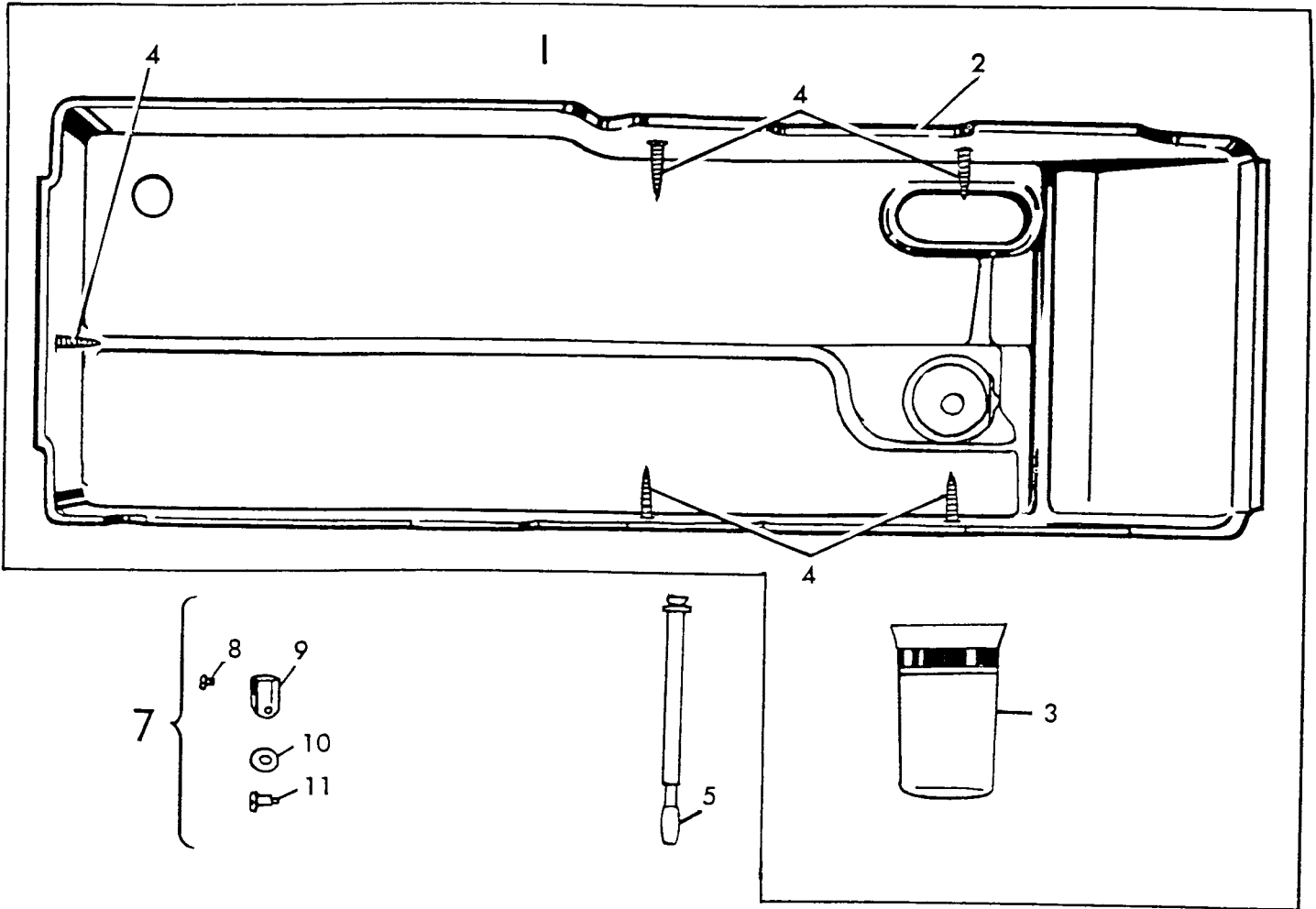

ACCESSORIES

BOBBIN WINDER (SWINGING AUTOMATIC, RIGHT HAND)
FOR "V" BELT DRIVE

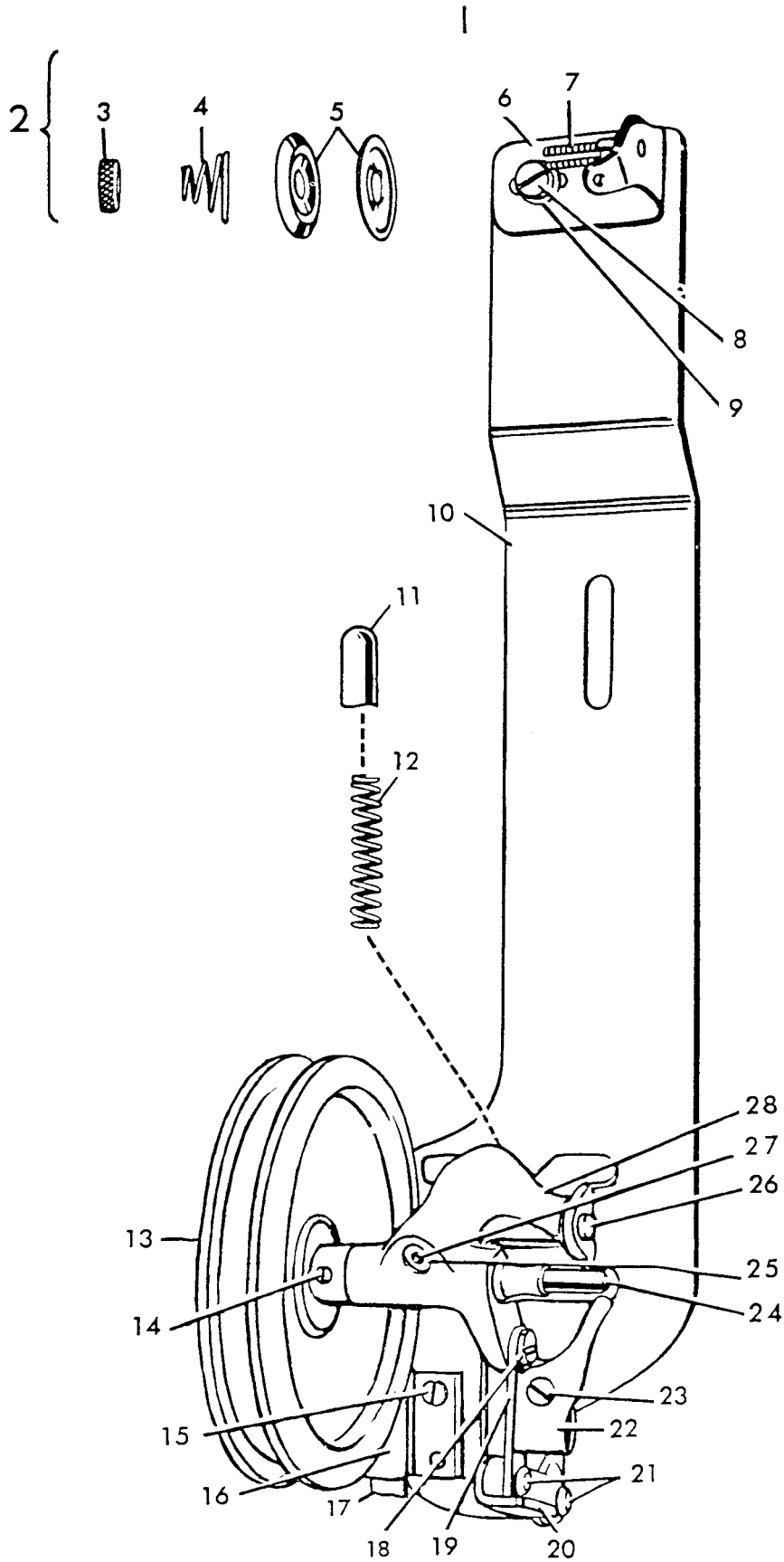

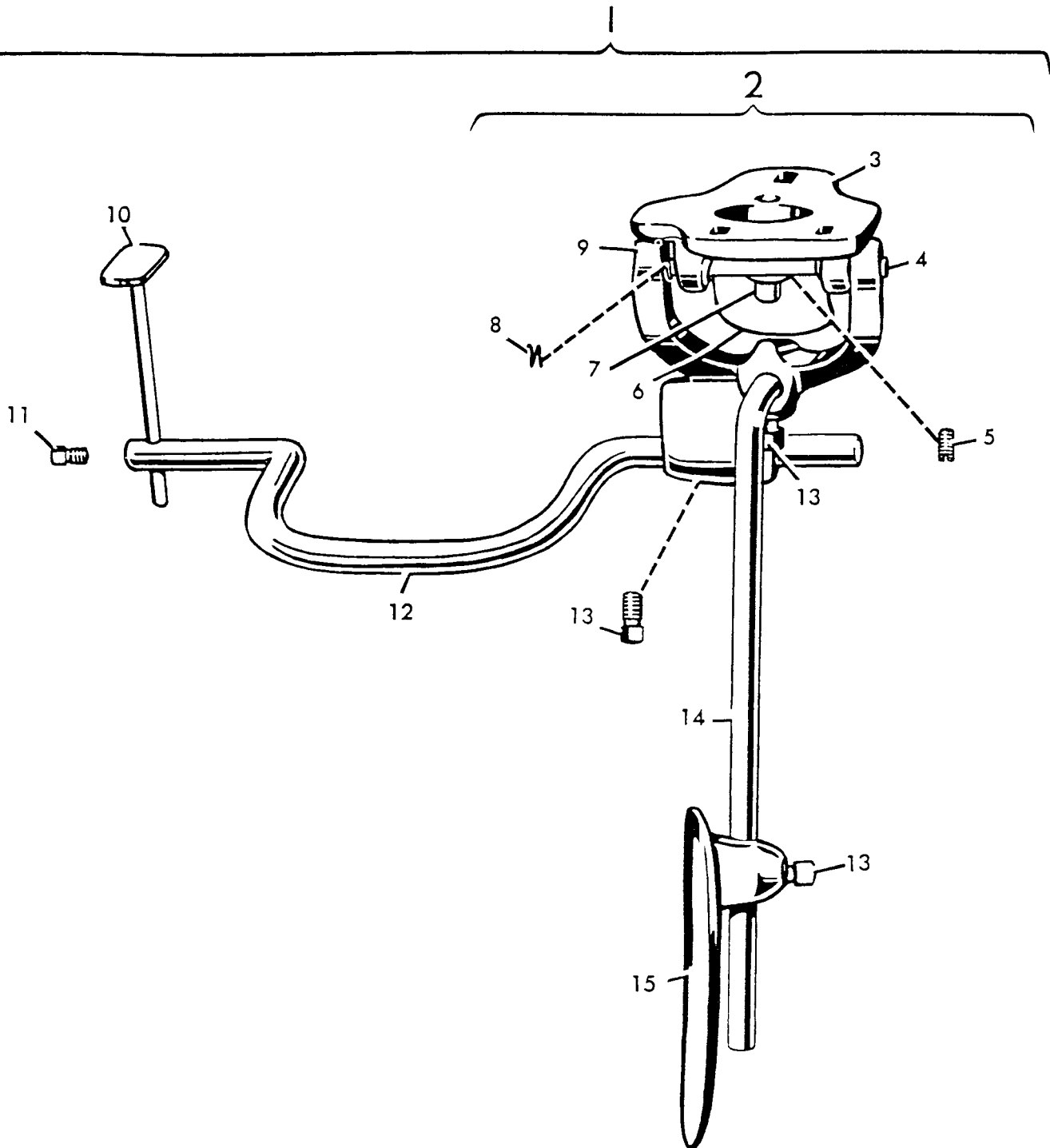
ACCESSORIES
KNEE LIFTER

NUMERICAL LIST OF PARTS

Part No.	Page No.	Part No.	Page No.	Part No.	Page No.	Part No.	Page No.
244071	14, 34	244761	24	267232	30	267374	36
244084	28	244762	24	267233	30	267388	16
♦244701	16	244763	24	267236	14	267395	16
♦244702	16	244764	24	267238	18	267396	16
244704	28	259428	34	267239	14	267397	16
244705	16	259429	34	267242	32	267398	16
244706	30	259462	34	267245	24	267399	16
244707	22	259660	34	267247	14	267400	16
244708	22	259662	34	267248	28	267466	14
244709	22	259990	34	267251	18	267623	24
244710	22	263093	24	267254	30	268063	22
244711	26	263554	28	267256	30	268064	24
244712	24	264714	14	267257	30	268065	24
244713	24	267031	22	267261	30	268066	24
244714	24	267032	22	267262	30	268067	26
244715	24	267033	24	267263	30	268197	16
244716	30	267034	22	267265	18	270026	24
244717	30	267053	28	267272	16	270653	22
244718	24	267063	24	267273	22	270880	28
244719	30	267139	28	267276	30	271017	16
244720	28	267140	28	267277	28	272142	14
244721	14	267152	16	♦267284	30	275049	18
244722	14	♦267158	14	♦267285	30	275050	18
244725	30	267160	14	267286	30	276061	28
244726	14	267161	14	267287	30	350197E	22
244727	20	267162	14	267289	18	350231C	36
244729	20	267166	28	267293	30	350366X	22
244730	22	267167	28	267315	20	350393C	22
244734	20	267172	28	267316	20	350405C	26
244735	20	267180	24	267321	30	350440X	24
244736	20	267182	24	267322	30	350464X	18
244737	20	267188	24	267323	20	350467C	24
244738	20	267190	24	267351	18	350477C	24
244739	20	267194	28	♦267355	26	350492C	14
244740	20	267197	32	267356	26	350548C	24
244741	20	267198	28	267358	26	350563E	16
244742	20	267200	28	267359	26	350564E	28
244743	20	267212	28	267360	28	350566C	30
244744	20	267215	28	267361	28	350574F	26
244745	20	267220	16	267362	30	350581C	18
244746	20	267221	14	267365	28	350588X	20
244747	14	♦267222	14	267366	28	350595XC	28
244750	18, 32	267224	14	267367	28	350708	32
244751	16	267229	30	267368	20		
244759	24	267230	30	267370	28		
244760	24	267231	30	267371	28		

OPERATORS INSTRUCTIONS FOR 211W151 MACHINE
TO OIL THE MACHINE

When the machine is received from the factory, it should be thoroughly cleaned and oiled.

Use "type A" or "type C" oil sold by Singer Sewing Machine Company.

Before starting the machine, draw back the bed slide cover A FIG. 2 and remove the oil dip stick gauge. Fill the oil reservoir in sewing hook saddle to full mark on the oil dip stick gauge. Return dip stick and close the bed slide cover A. Fill oil reservoir on top of the arm, through oil filler hole B FIG. 2 to high mark on oil sight C FIG. 2. Fill the face plate reservoir with thread lubricant through oil filler hole F FIG. 2. The lever G FIG. 2 is shown in an open position; to close, push up or down. Push down and turn oil control plunger D FIG. 2 until it locks in down position. Release plunger if machine is to be left more than an hour.

CAUTION: Oil control, plunger D must be locked in a down position before starting machine.

To lubricate the hook and opener gears, a generous supply of oil should be applied AT LEAST TWICE DAILY to oil hole next to the hook base.

When machine is in continuous use, the oil reservoir should be checked twice daily.

SPEED

The speed recommended for this machine is 4000 R.P.M. depending on material being stitched. It is advisable to run a new machine slower than the maximum speed for the first few minutes, to allow time for the oil to reach the moving parts. The machine pulley turns over towards the operator.

NEEDLES

Needles for Machine 211w151 are of Class and Variety 135 x 7, which are made in sizes 12,14,16,18,20 and 21.

TO REMOVE THE BOBBIN

Draw back the bed slide cover. Turn the machine pulley over toward you until the needle bar moves up to the highest point. Raise the bobbin case latch and lift out the bobbin.

TO REPLACE THE BOBBIN AND THREAD THE BOBBIN CASE

Hold the bobbin between the thumb and forefinger of the right hand, pass the thread on the bottom from left to right and place it on the center stud of the bobbin case, then push down the bobbin case latch. Draw the thread into the slot at the edge of the bobbin case and back of the projecting part of the bobbin case, leaving a loose end of thread about two inches long above the bed slide. When closing the bed slide, leave just enough space for the thread to pass through.

TO THREAD THE NEEDLE

Pass the thread from the spool stand, down through the thread guide on top of the arm and then as shown in FIG. 2.

TO REGULATE THE TENSIONS

The tension on the needle thread is regulated by a thumb nut at the front of the tension discs on the front of the machine. To increase the tension, turn the thumb nut over to the right. To decrease the tension, turn the thumb nut over to the left.

The tension on the bobbin thread is regulated by means of the screw nearest the center of the tension spring on the outside of the bobbin case. To increase the tension, turn the screw over to the right. To decrease the tension, turn the screw over to the left.

TO REGULATE THE LENGTH OF STITCH

The number of stitches per inch is stamped on the machine pulley FIG. 2, located on the arm shaft.

To change the length of stitch, press down the plunger E FIG. 2 in the bed of the machine and at the same time, turn the machine pulley slowly until the plunger enters a notch in the adjustable feed eccentric cam. Still holding the plunger, turn the machine pulley over a part of a revolution, until the desired number of stitches per inch on the machine pulley is opposite the reference mark on the arm, then release the plunger.

TO SET THE NEEDLE BAR

See that the needle is up in the holder as far as it will go. There are two lines across the needle bar, about two inches above the lower end. When the needle bar is at its lowest position, the upper mark should be just visible at the end of the needle bar frame.

TO SET THE SEWING HOOK TO OR FROM THE NEEDLE

To prevent the point of the hook from dividing the strands of the thread, they should run as close to the needle (within the scarf) as possible.

Turn the machine pulley over toward you, until the point of the sewing hook is at the center of the needle. Loosen the two screws H and J FIG. 3 underneath the bed of the machine and move the hook saddle to the right or left, as may be required, until the point of the hook is as close to the needle as possible, without striking it, then securely tighten the two screws H and J.

TO ADJUST TIMING OF BOBBIN CASE OPENER

Draw back the bed slide cover A FIG. 2. Turn the machine pulley over towards you, until the lowest timing mark on the needle bar is even with the end of the needle bar frame on the upward stroke. In this position, the timing mark on the flange of the opener shaft should line up with the reference mark on the hook saddle. If opener shaft is out of time, tip the machine back and loosen the opener driving gear set screws, then return machine to upright position and turn shaft with screwdriver at top end of shaft, then tighten the two opener driving gear set screws.

TO RAISE OR LOWER THE FEED DOG

Usually, when the feed dog is at its highest position, it should show a full tooth above the throat plate.

Remove the throat plate, clean the lint and dust from between the feed slot and replace the throat plate; tip the machine back and turn the machine pulley towards you until the feed dog is at its highest position; loosen the screw K FIG. 3 in the feed lifting cam fork and raise or lower the feed dog, as may be required. Then tighten the screw K.

When raising or lowering the feed dog, be careful that its underside does not drop low enough to strike the sewing hook.

The feed dog should be set so that, when the needle is down, it should be slightly in front of the center of the needle hole (toward the operator). In case the needle does not enter the hole, in the feed dog correctly, loosen the pinch screws P FIG. 3 and adjust the feed dog as required, then securely tighten the pinch screws P.

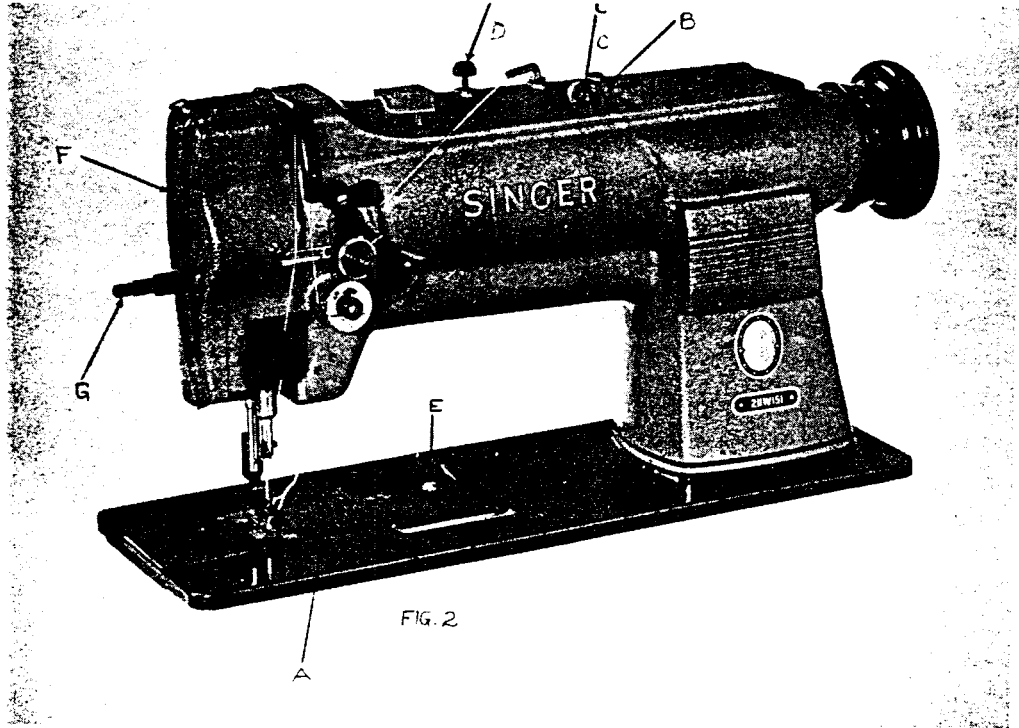

FIG. 2

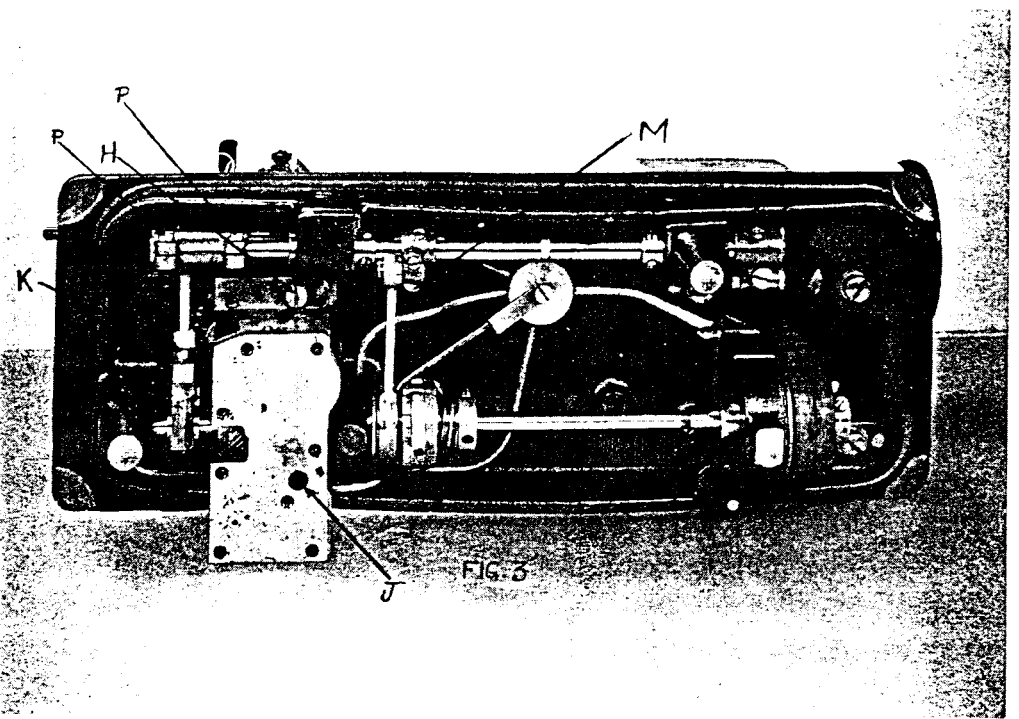

FIG. 3