

**SINGER**  
**231-4 AND 231-5**

# USE ONLY SINGER OILS and LUBRICANTS

*They insure freedom from lubricating trouble and  
give longer life to sewing equipment*

## “Singer Oil for High Speed Sewing Machines”

(Cloth and Leather)

For all manufacturing sewing machines except where a stainless oil is desired.

## “Singer Stainless Oil for High Speed Sewing Machines”

For all manufacturing sewing machines where a stainless oil is desired.

## “Singer Motor Oil”

For oil-lubricated motors, power tables, transmitters and machinery in general.

## “Singer Stainless Thread Lubricant”

For lubricating the needle thread of sewing machines for stitching fabrics or leather where a stainless thread lubricant is required.

*NOTE: All of the above oils are available in 1 quart, 2 quart, 1 gallon and 5 gallon cans or in 55 gallon drums, and can also be supplied in customer's containers.*

## “Singer Gear Lubricant”

This specially prepared grease is recommended for gear lubrication on manufacturing sewing machines.

## “Singer Ball Bearing Lubricant”

This pure grease is specially designed for the lubrication of ball bearings and ball thrust bearings of motors and electric transmitters, ball bearing hangers of power tables, etc.

*NOTE: The above greases are furnished in ¼ lb. tubes and 1 lb. and 4 lb. tins.*

Copyright, U. S. A., 1923, 1931, 1935, 1938 and 1939,  
by The Singer Manufacturing Company  
All Rights Reserved for all Countries

# INSTRUCTIONS

FOR USING AND ADJUSTING

# SINGER SEWING MACHINES

## 231-4 and 231-5

## Feed - Off - The - Arm

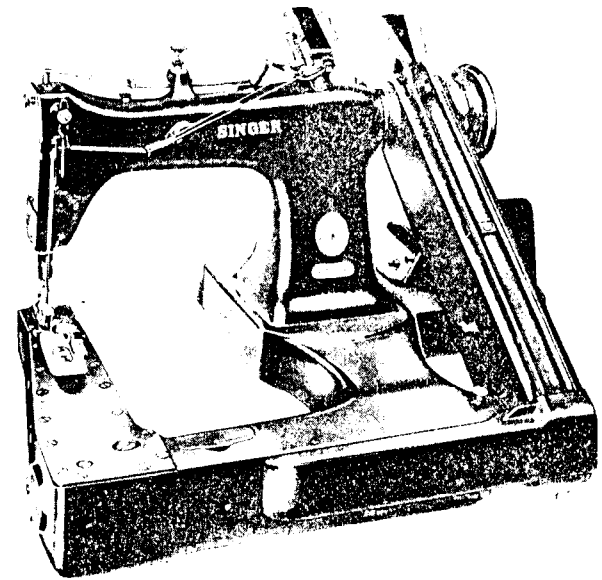

TWO NEEDLES AND TWO LOOPERS  
TWO-THREAD CHAIN STITCH

THE SINGER MANUFACTURING CO.

To all whom it may concern:

The placing or renewal of the name "Singer" (Reg. U. S. Pat. Off.) or any of the trade marks of The Singer Manufacturing Company on any machine that has been repaired, rebuilt, reconditioned, or altered in any way whatsoever outside a Singer factory or an authorized Singer agency is forbidden.

---

**THE IMPORTANCE OF USING  
GENUINE SINGER PARTS AND NEEDLES  
IN SINGER MACHINES**

The successful operation of Singer machines can only be assured if genuine Singer parts and needles are used. Supplies are available at all Singer Shops for the Manufacturing Trade and mail orders will receive prompt attention.

Genuine Singer Needles should be used  
in Singer Machines.  
These Needles and their Containers  
are marked with the  
Company's Trade Mark "SIMANCO." 1

Needles in Containers marked  
"For Singer Machines"  
are not Singer made needles. 2

**DESCRIPTION**

FEED-OFF-THE-ARM MACHINE 231-4 has two needles and two loopers and makes the two-thread chain stitch for lap seam felling shirts, underwear, pajamas and similar tubular work in light and medium weight materials.

The machine may be furnished in gauges from 3/32 to 3/8 inch, as ordered.

A splash oiling system oils the feed and looper mechanism. The needle bar driving mechanism is oiled through a hollow shaft from an oil reservoir at the balance wheel end.

MACHINE 231-5 is the same as Machine 231-4 except that the needles are in reverse position, for closing shirts when the cuff is attached to the sleeve before closing.

**CAUTION**

After setting up, do not start the machine, not even to test the speed, until it has been thoroughly oiled, as instructed on pages 6 and 7.

### Speed

The machine should be driven at a speed not exceeding 4000 revolutions per minute for the first two or three days, after which it can be driven up to its maximum speed of 4300 revolutions per minute, depending on the nature of the work and the ability of the operator. When the machine is in operation, the top of the balance wheel turns toward the operator.

### Setting Up

Unpack and clean the machine. Attach the counterweight to the machine bed as shown in Fig. 5. Insert the two rubber cushions (O, Fig. 2) into the holes in the base of the machine. Place the machine in position with the edge of the machine base in line with the edge of the table as shown below, and see that the hole (N) for the presser bar lifter chain is in line with the hole in the table plank.

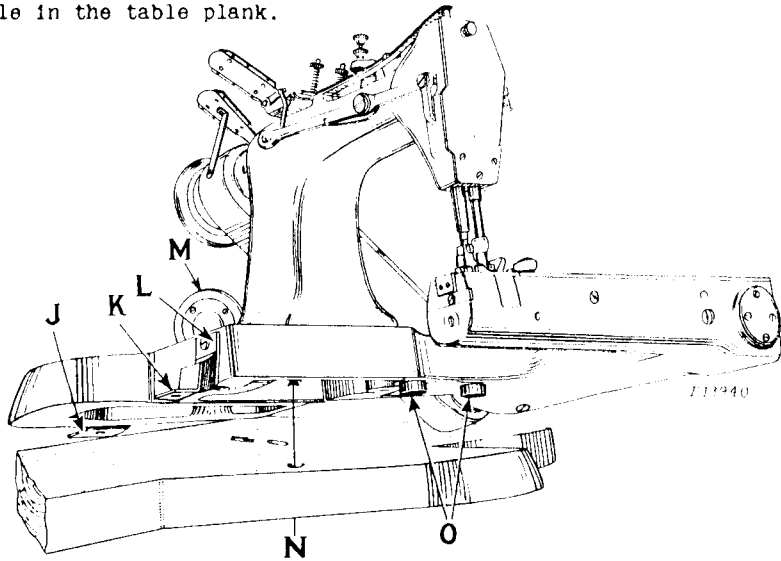

Fig. 2

The two vibration dampeners (J and K, Fig. 2) are placed at the rear of the machine base and at the right of the counterweight as shown in Fig. 2. Attach the straight straps (L) to the machine base and counterweight, then locate and drill holes in the table and fasten the angle straps (K) of the dampeners to the table with 1/4 X 2 1/4 inch bolts.

The cylinder arm cover of the machine should be levelled by placing shims under the rubber cushions or the vibration dampeners. Place a spirit level crosswise on the flat arm cover plate, and set the machine with its arm rotary shaft perfectly level so that the oil will not flood the needle bar driving mechanism in the head. Then place the spirit level lengthwise on the flat cover plate and set the arm of the machine level. Check the setting occasionally to keep the machine level.

When the machine is operated on a Singer Electric Transmitter Power Table or a Low Shaft Power Table, the idler pulley (M, Fig. 2) is attached to the machine counterweight as shown in Fig. 5.

## Oiling the Machine

Use only "Singer Stainless Oil for High Speed Sewing Machines" for the lubrication of this machine.

See "X-ray" view of machine on pages 12 and 13.

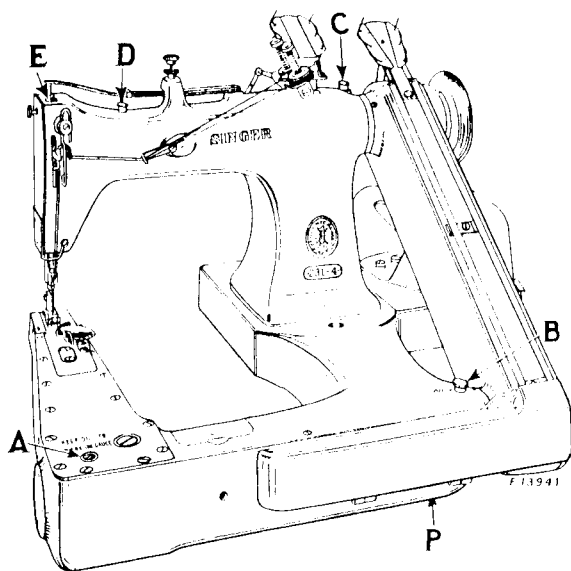

Fig. 3

All of the oil is drained from the cylinder arm reservoir before the machine is shipped from the factory, therefore it is absolutely necessary that the machine be thoroughly oiled according to the following instructions before it is started in operation:

1. After the machine has been set up so that its cylinder arm cover is level, lift out the gauge (A, Fig. 3) and fill the arm reservoir to the level of the mark on the gauge. Run the machine a few minutes, then wipe off the gauge and recheck the oil level. THIS RESERVOIR SHOULD BE FILLED ABOUT TWICE A WEEK OR OFTEN ENOUGH TO KEEP THE OIL LEVEL UP TO THE MARK ON THE GAUGE.

2. Turn the balance wheel to bring the screw plug (F, Fig. 4) to the top, remove this plug and fill the reservoir practically to the top. THE OIL LEVEL IN THIS RESERVOIR SHOULD NEVER BE ALLOWED TO GO BELOW THE HOLE AT THE CENTER OF THE ARM SHAFT. If the oil is down to the bottom of this hole, add oil before starting. Otherwise run the machine a few minutes before adding oil to this reservoir.

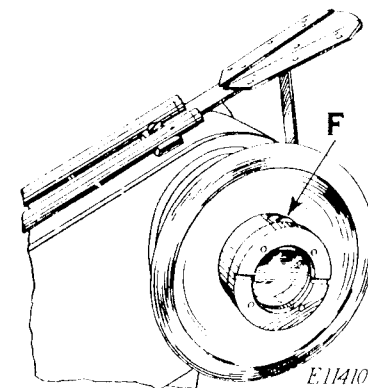

Fig. 4

3. Place about 5 drops of oil in each of the three cups (B, C and D, Fig. 3) which lubricate the ball bearings, and in the cup (G, Fig. 5) on the idler pulley underneath the balance wheel. DO THIS ABOUT ONCE A WEEK.

NOTICE: When the machine is first set up, or after it has stood idle for some time, put a few drops of oil in the top of the needle bar guide pin (E, Fig. 3) before starting the machine.

OIL DRAIN. Surplus oil from the bearings drains into the wells at the rear of the base (H, Fig. 5) and in the head of the arm (LL, Fig. 17). These wells may be kept empty by soaking out the oil with waste or similar material.

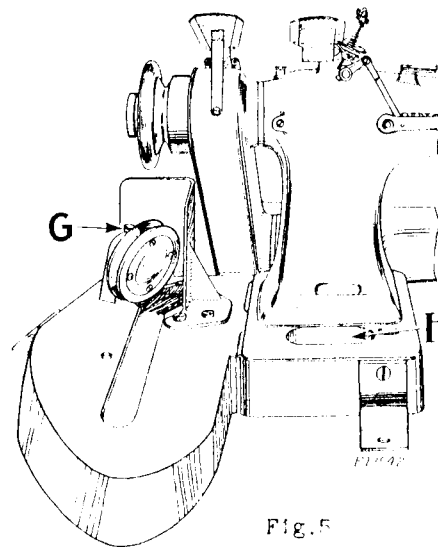

Fig. 5

Oil which accumulates in the front of the arm under the rotary shaft should be drained out occasionally by removing the screw plug at (P, Fig. 3) in the bottom of the arm, to prevent oil from getting on the looper thread take-up.

Note: If an excessive amount of oil should flow into the reservoir (LL, Fig. 17), see instructions for replacing the wicking in the arm shaft crank on page 23.

## Needles

Needles for Machines 231-4 and 231-5 are of Class and Variety 149X1 and are made in sizes 11, 14, 16, 17, 18 and 19.

The size of the needles to be used should be determined by the size of the thread, which must pass freely through the eyes of the needles. If rough or uneven thread is used, or if it passes with difficulty through the eyes of the needles, the machine cannot stitch perfectly.

Orders for needles must specify the QUANTITY required, the SIZE number, and the CLASS and VARIETY numbers separated by the letter x.

The following is an example of an intelligible order:  
"100 No. 17, 149x1 Needles"

The best stitching results will be obtained when using the needles furnished by the Singer Sewing Machine Company.

### To Set the Needles

Turn the balance wheel over toward you until the needle bar moves up to its highest point, and loosen the two set screws in the needle clamp. Place the needles up into the needle clamp as far as they will go, with the single continuous groove in each needle toward you, then tighten the two set screws.

### Threading the Needles

Turn the balance wheel until the needle bar is at its highest point.

TO THREAD THE LEFT NEEDLE, bring the thread from the left spool (A1, Fig. 6) on the unwinder, down through the hole (A2) in the thread guide bar, then down through each of the eyelets (A3, A4 and A5, Fig. 7) in the thread straightener as shown. Pass the thread through eyelet (A6), around between the rear tension discs (A7), through eyelet (A9), through the rear eyelets in the thread guide (A9, Fig. 8) and the take-up thread guides (A10 and A11), down under the retainer spring and through the rear eyelet (A12) in the take-up, down behind the wire guide (A13), and from front to back through the eye of the left needle (A14).

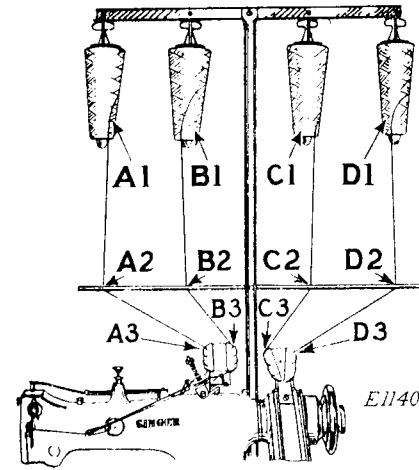

Fig. 6

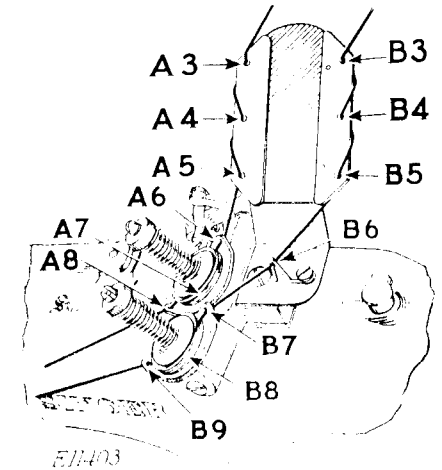

Fig. 7

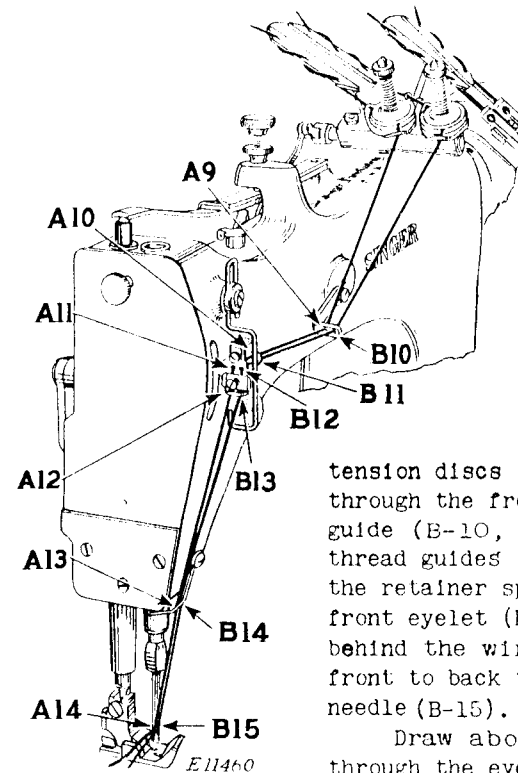

Fig. 8

TO THREAD THE RIGHT NEEDLE, bring the thread from the second spool (B-1, Fig. 6) on the unwinder, down through the hole (B-2) in the thread guide bar, then down through each of the eyelets (B-3, B-4 and B-5, Fig. 7) in the thread straightener as shown. Pass the thread through the wire guide (B-6), through eyelet (B-7), around between the front

tension discs (B-8), through eyelet (B-9), through the front eyelets in the thread guide (B-10, Fig. 8) and the take-up thread guides (B-11 and B-12), down under the retainer spring and down through the front eyelet (B-13) in the take-up, down behind the wire guide (B-14) and from front to back through the eye of the right needle (B-15).

Draw about two inches of thread through the eyes of the needles with which to commence sewing.

### Threading the Loopers

Turn the balance wheel until the needle bar is at its lowest point to bring the loopers into position for threading. Swing open the cover plates at the right of the throat plate and on the front and top of the horizontal arm.

TO THREAD THE FRONT LOOPER or the one nearest the operator, bring the thread from the right-hand spool (D1, Fig.6) on the unwinder, down through the hole (D2) in the thread guide bar, then downward through each of the eyelets (D3, D4 and D5, Fig. 9) in the thread straightener as shown.

Pass the thread through the ferrule at the end of the thread tube (D6) and out through the hole at (D7), then pass it from the hole at (D8) down through the lower ferrule of the thread tube, as shown in Fig. 10. The thread will automatically slip through the spiral

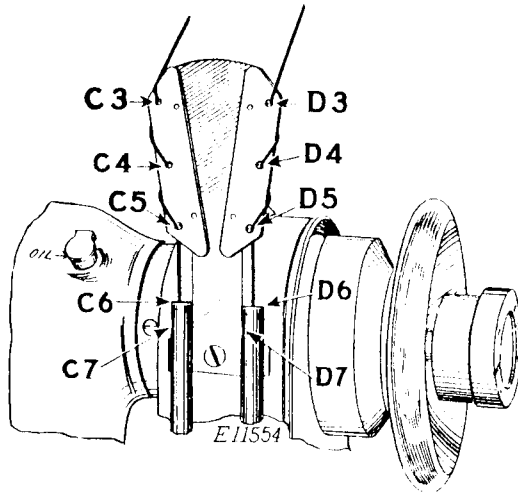

Fig.9

slot into the tube. In the same way, pass the thread through the lower horizontal tube (D9), then between the first and second tension plates (D10), back through the front eyelet (D11), through the hole in the casting into the wire guide (D12), under the

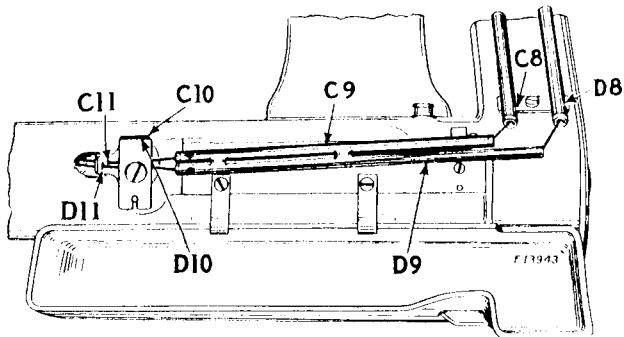

Fig.10

take-up stripper (D13), into the guide (D14), into the front slot (D15) and under the wire guard, down behind the thread retaining plate (D16), through the thread tube (D18), through the front hole (D19) in the looper thread guide, through the hole (D20) in

the heel of the front looper, and from front to back through the eye (D21) of the looper.

TO THREAD THE REAR LOOPER, bring the thread from the spool (C1, Fig.6) on the unwinder, down through the hole (C2) in the

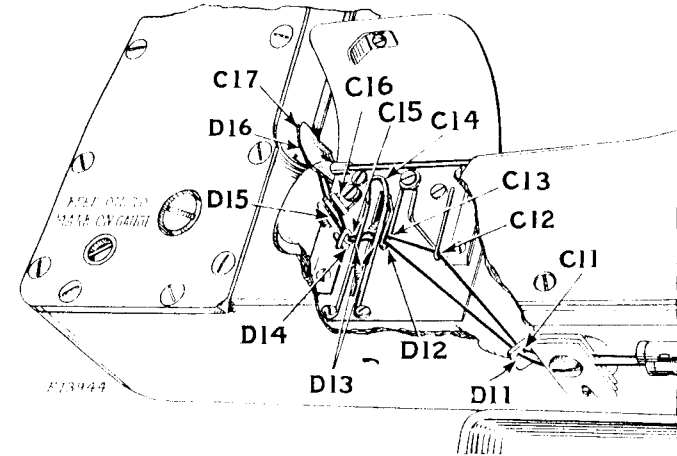

Fig.11

thread guide bar, then downward through each of the eyelets (C3, C4 and C5, Fig.9) in the thread straightener, as shown. Pass the thread through the ferrule at the end of the thread tube (C6) into the hole at (C7), then from the hole at (C8) through the lower ferrule of the thread tube, as shown in Fig.10, allowing the thread to slip through the spiral slot into the thread tube. In the same way, pass the thread through the upper horizontal tube (C9), between the second and third tension plates (C10), back through the rear eyelet (C11),

through the hole in the casting into the wire guides (C12 and C13), under the take-up stripper (C14), into the guide (C15), into the rear slot (C16) and under the wire guard, down behind the thread retaining plate (C17), through the thread tube (C19), through the rear hole (C20) in the looper thread guide, through the hole (C21) in the heel of the rear looper and from front to back through the eye (C22) of the looper.

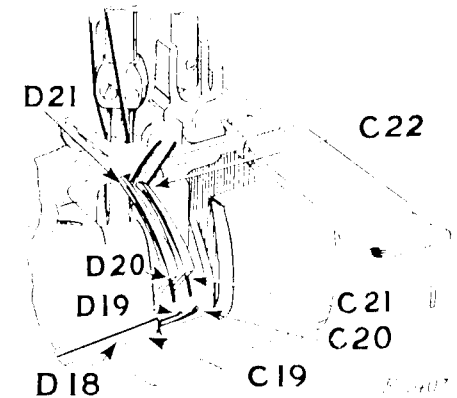
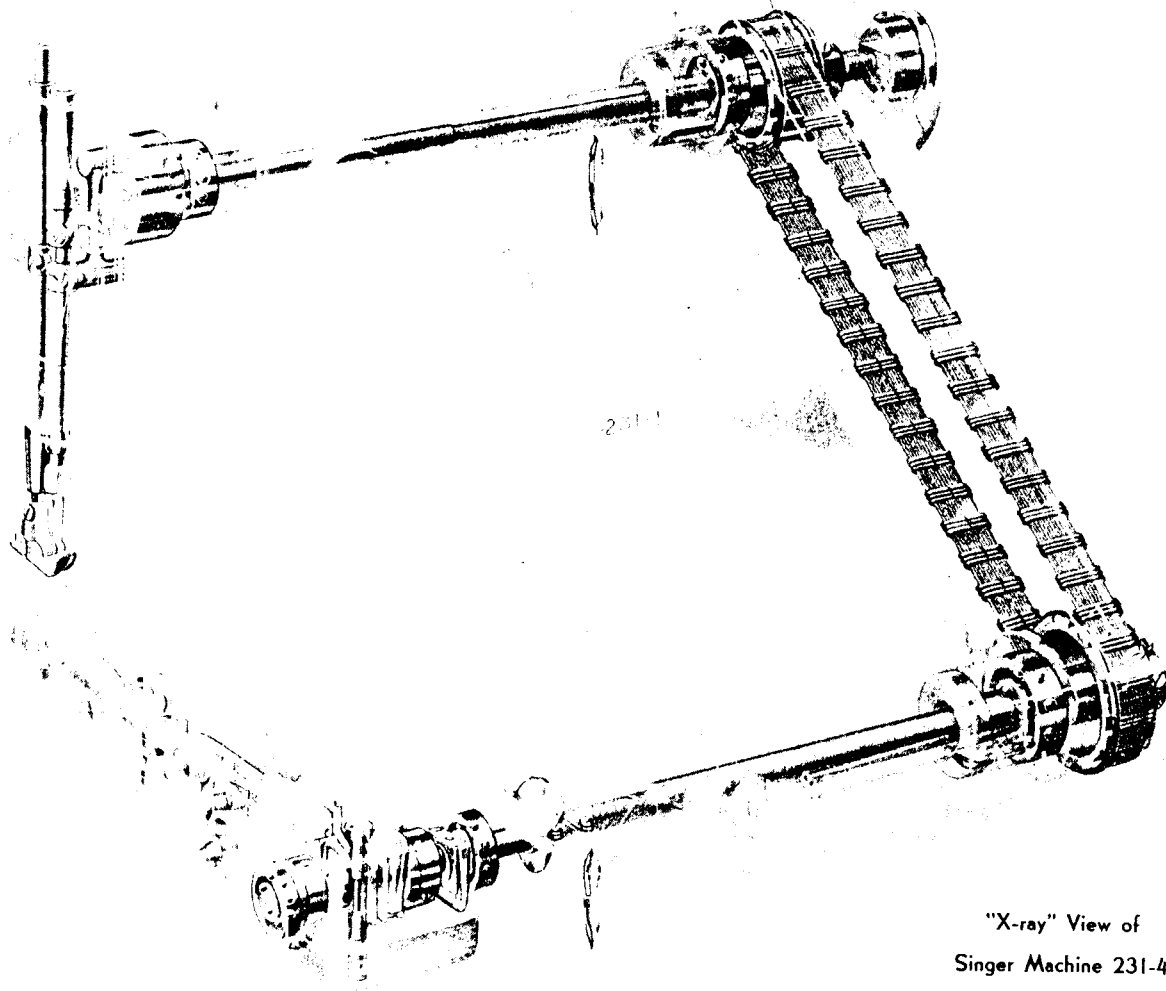

Fig.12

Draw about two inches of thread through the eye of each looper with which to commence sewing.



"X-ray" View of  
Singer Machine 231-4



### To Regulate the Pressure on the Material

The pressure of the presser foot on the material should be heavy enough so that the feed will move the work evenly. To in-

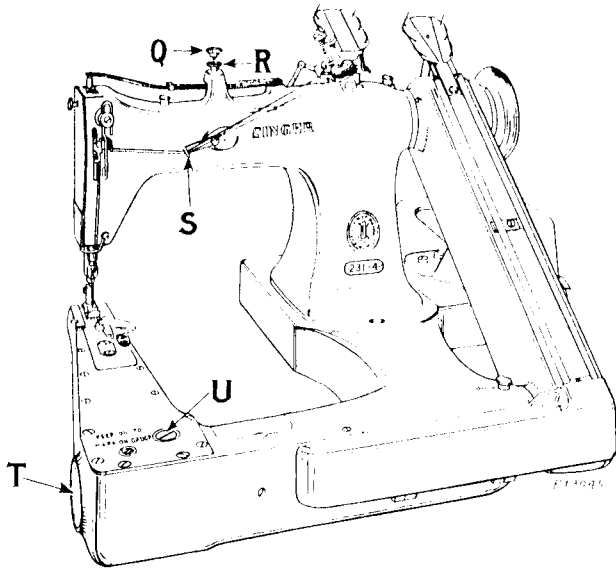

Fig.13

crease the pressure, loosen the lock nut (R, Fig.13) and turn the thumb screw (Q) downward. To decrease the pressure, turn the thumb screw upward. Then tighten the lock nut.

### To Regulate the Tensions

The tension on the needle threads is regulated by the thumb nuts above the tension discs at the top of the machine. The needle threads require sufficient tension to set the stitch properly in the goods.

The tension on the looper threads is regulated by turning the screw at the front of the looper thread tension plates (D10, Fig.10) to the right for more tension or to the left for less tension. The looper threads should have only enough tension to control the thread.

### To Regulate the Length of Stitch

The length of the stitch is controlled by the feed eccentric, which may be adjusted by removing the screw plug (U, Fig.13) in

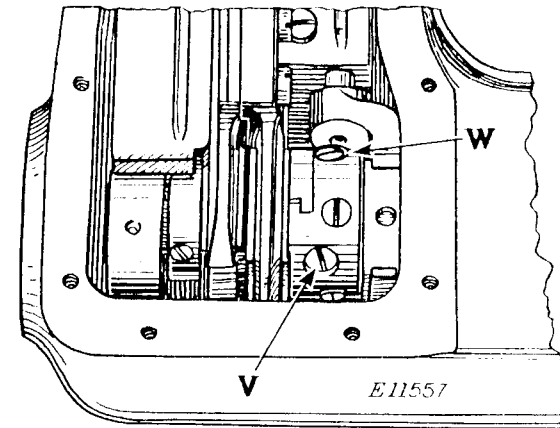

Fig.14

the front of the bed cover. First turn the balance wheel to bring the lock screw (V, Fig.14) underneath the hole, and loosen this lock screw. Then turn the large screw (W) which projects beyond the body of the eccentric, to the left or outward for a longer stitch, or to the right for a shorter stitch. Tighten the lock screw (V) and replace the screw plug.

## INSTRUCTIONS FOR ADJUSTERS AND MECHANICS

### To Time and Set the Loopers in Relation to the Needles

The loopers should be at the end of their backward stroke, with the points farthest from the needles, at the same time that the needle bar is at its lowest point. In this position, the point of the front looper should be about  $9/64$  inch from the center of the front needle. The loopers may be moved to this position after loosening the clamping screw (CC, Fig. 15). The looper timing is set by having the first (when turning toward the operator) of the two set screws in the looper eccentric (S2, Fig. 21) bear against a flat on the shaft.

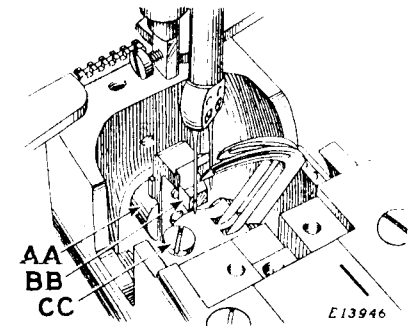

Fig. 15

If the belt has been removed or disturbed, the lower shaft must be timed by loosening the two set screws and the cap screw (E2 and F2, Fig. 20) in the lower belt pulley, and turning the lower shaft until the loopers are correctly timed with the needles. Tighten the cap screw (E2) first, then the two set screws.

### To Time the Needle-Avoiding Motion of the Loopers

The sidewise or needle-avoiding motion is produced by the eccentric at the right of the feed eccentric, on the lower shaft. The loopers should just clear the back of the needles on their forward stroke, and should clear the front of the needles on the backward stroke. A change in the timing of the eccentric will make the loopers come closer to or farther from the needles and therefore a different setting is required for different sizes of needles. This eccentric is set for size 17 needles when the machine leaves the factory.

To adjust the eccentric, remove the arm cover and turn the balance wheel until one of the two set screws appears under the hole (V2, Fig. 21). Loosen this screw about a quarter-turn, leaving it below the surface of the eccentric so that it will not score the inside of the bearing. Bring the other set screw under the

hole, loosen it and leave the screwdriver in the slot to hold the eccentric while turning the shaft to obtain the desired adjustment.

To bring the loopers the same distance from the needles on their forward and backward strokes, they may be moved sideways on the looper shaft after loosening clamping screw (CC, Fig. 15).

### To Set the Needle Guard

The function of the needle guard (BB, Fig. 15) is to prevent the needles springing into the path of the loopers when the loopers are on their forward stroke. The needle guard should be set as close as possible to the needles without touching them. To set the needle guard, loosen the set screw (FF, Fig. 16) underneath the end of the cylinder arm and move the needle guard to the correct position.

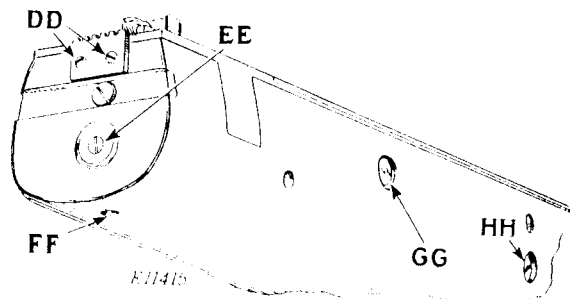

Fig. 16

### To Set the Feed Dog at the Correct Height

When the feed dog is at its highest point, practically the full depth of the teeth should project through the slots in the throat plate. The feed dog may be raised or lowered by turning the eccentric pin (GG, Fig. 16) a part of a turn in either direction. It is not necessary to lock this eccentric pin, as the necessary friction is provided by pressure of a set screw and lock nut inside the bed.

### Thread Cutter

To remove the thread cutter blade for honing, take out the two screws (DD, Fig. 16).

### To Set the Needle Bar

When the points of the loopers reach the centers of the needles on the upward stroke of the needle bar, the eyes of the needles should be about 1/8 inch below the looper points, so that the eyes of the needles and the eyes of the loopers will be in perfect alignment when they pass each other.

The needle bar may be raised or lowered after loosening the clamping screw (MM, Fig. 17).

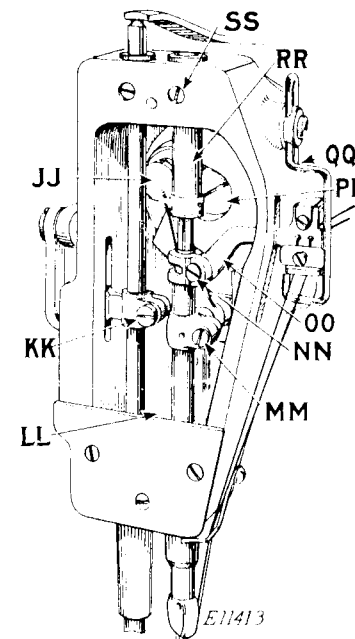

Fig. 17

### To Set the Needle Thread Take-up

The needle thread take-up (OO, Fig. 17) is usually set so that the top of its clamp is about 1/16 inch below the top of the needle bar.

### Adjustment of the Auxiliary Thread Take-up

The auxiliary thread take-up (QQ, Fig. 17) at the front of the machine should be set high enough so that it takes up the slack of the needle threads after the loopers have shed the needle loops and as the needle bar finishes its downward stroke and the stitch is set.

For some threads it will be necessary to set the auxiliary thread take-up at a height different from that required by others, owing to the differences in finish, twist, elasticity, etc.

### To Set the Needle Thread Eyelet

The needle thread eyelet (S, Fig. 13) should be set so that when the loopers are shedding the needle loops on their backward stroke, the thread will not snap off the points of the loopers nor be drawn through the tension discs with enough tension to break the thread.

To set the needle thread eyelet, it is best to start it in a low position and continue raising it until the loopers back out of the needle loops with a little tension on the thread.

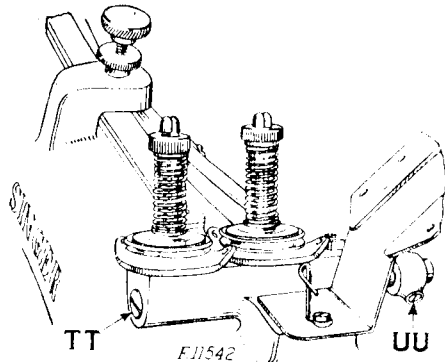

Fig. 18

### To Adjust the Needle Thread Tension Releaser

The function of the needle thread tension releaser is to release the tension on the needle threads when the presser foot is raised. If the tension releaser does not release the threads when the presser foot is raised, or if the tension is partially released when the presser foot is down, loosen the set screw (UU, Fig. 18) and turn the shaft (TT) to the right or left until the correct adjustment is obtained, then tighten the set screw.

### To Time the Looper Thread Take-up

The straight part of the take-up (VV, Fig. 19) should touch the thread between the take-up stripper wires (WW) just as the loopers

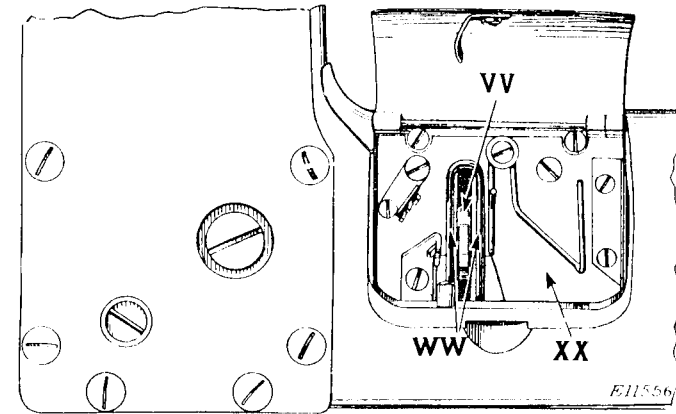

Fig. 19

start their backward or loop-shedding motion. The take-up acts also as a thread pull-off and should draw most of the thread through the tension discs on the backward stroke of the loopers, so that the loopers on their forward stroke will just draw the thread taut or pull a small amount of thread.

The take-up may be advanced to draw more thread during the back stroke, or retarded to draw less thread, after loosening the set screw in the hub of the take-up.

### To Time the Feed

The set screw (T-2, Fig. 21) in the feed eccentric should bear against the flat on the shaft.

The feed lifting eccentric is connected to the looper eccentric and is timed as instructed on page 17.

## To Remove and Replace the Arm Shaft Connection Belt

Remove the needles to prevent damage while the needles and loopers are out of time. Unscrew the balance wheel oil reservoir from the shaft. Loosen the two set screws in the balance wheel belt groove, and remove the balance wheel. Take out the two screws which hold the belt guard cover and remove the cover. The belt may be easily slipped off the lower belt pulley, then the upper pulley.

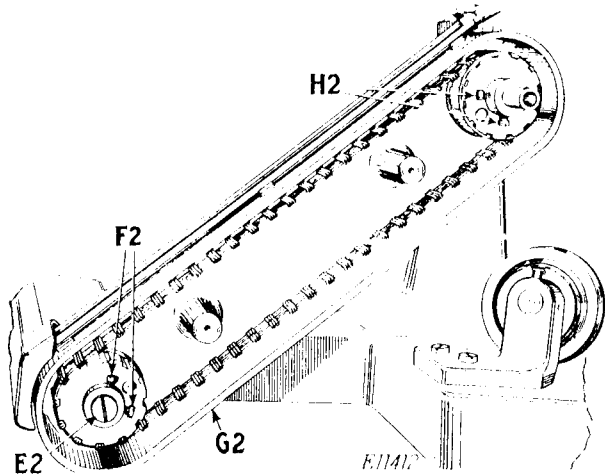

Fig. 20

When replacing the belt, first place it over the upper pulley, having the needle bar at its highest point. Turn the lower pulley until the feed dog is up and the loopers all the way forward. Keeping the pulleys in time with each other, place the belt on the lower pulley.

If the upper pulley is removed or disturbed, it should be reset as follows when replacing the belt. Turn one of the set screws (H-2, Fig. 20) lightly into the groove in the arm shaft, then place the belt on the pulleys and hang the belt guard cover over the shaft. Place the balance wheel on the shaft and turn one of the set screws in the belt groove lightly into the groove in the shaft. Insert and tighten the arm shaft oil reservoir to draw the pulley against the ball bearing. Tighten the two set screws (H-2) in the upper pulley and also those in the belt groove of the balance wheel. The belt guard cover may be swung out of the way without removing the balance wheel, in order to reach the lower pulley for timing the lower shaft.

## To Remove the Arm Shaft

(See Fig. 17)

Remove face plate, presser foot and needles. Remove the balance wheel, belt guard cover and belt, as instructed on page 22. Remove the upper belt pulley. Loosen the presser bar lifter bracket clamp screw (KK, Fig. 17) and withdraw the presser bar from the top. Loosen clamp screws (MM and NN), remove the thread take-up and allow the needle bar to drop downward. Loosen set screw (SS) and tap the needle bar guide pin (RR) out through the top. Then tap the shaft out through the needle bar end, with the crank, oil retainer ring and ball bearing.

TO REMOVE ONLY THE ARM SHAFT CRANK, lower the needle bar and remove the presser bar as instructed above, take out the large cap screw (PP, Fig. 17) in the crank, and loosen the two large set screws in its perimeter which are accessible through the hole in the rear of the casting. The smaller screw which is also visible through the hole in the casting should not be molested. The crank may then be removed from the shaft.

When replacing the arm shaft crank, it is important to have the pin (JJ) opposite the oil hole in the shaft, in which position the two set screws will be opposite flats on the shaft. Turn the set screws loosely against the flats, tighten the large cap screw (PP), then tighten the set screws.

## To Replace the Wicking in the Needle Bar Link Hinge Stud

The supply of oil in the reservoir at the center of the balance wheel should ordinarily last for about two days before it goes below the center of the hole in the shaft. If too much oil is lost into the well around the needle bar, a longer piece of wicking should be packed in the needle bar link pin in the arm shaft crank. This wick may be seen in the illustration on pages 12 and 13.

Remove the presser bar and drop the needle bar as instructed above, then remove the needle bar link. The wick may be replaced without removing the arm shaft crank.

## To Remove the Lower Rotary Shaft

Remove the arm shaft connection belt, the belt pulleys and the belt guard (G2, Fig. 20). Remove the horizontal thread tube plate at the front of the bed, and loosen the set screw underneath it which holds the right ball bearing case. Remove the take-up stripper plate (XX, Fig. 19) and loosen the set screw in the take-up (VV, Fig. 19). Loosen the two set screws in the intermediate ball

bearing hub, which is just to the left of the take-up. Loosen one of the set screws in the looper avoiding-motion eccentric (V2, Fig. 21), but do not back the screw out far enough to score the bearing when the shaft is turned to bring the other set screw under the hole. Back out the second screw into the hole in the sleeve to hold the eccentric in position when the shaft is removed. Loosen the two set screws (T2 and U2) in the feed eccentric, also the two set screws in the feed lifting and looper motion eccentric (S2). Remove the plate (T, Fig. 13) and take out the cap screw at the left end of the shaft. Withdraw the shaft, with the right bearing case, from the pulley end.

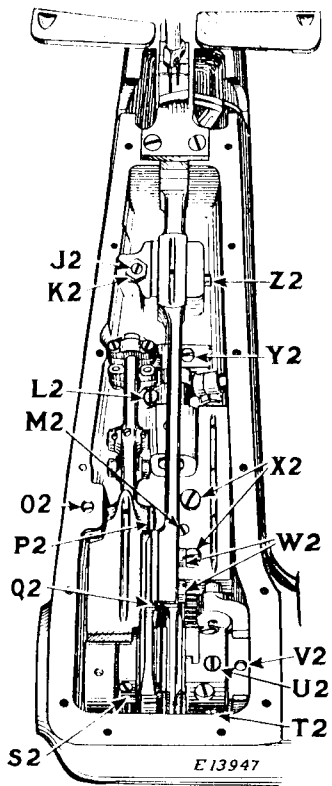

Fig. 21

To remove the looper driving mechanism complete, first remove the lower rotary shaft. Loosen the set screw (O2, Fig. 21) and drive out the top pin (P2). Loosen the two set screws in the collar directly under the pin (P2), and the set screw (M2), then unscrew the lower pin (HH, Fig. 16). The entire assembly may now be lifted out.

Remove the two screws (X2) and lift out the block with the looper avoiding-motion shaft and fork.

### To Remove the Feed Bar

Remove the presser foot, throat plate and feed dog. Loosen nut (K 2, Fig. 21) and back out the friction screw (J2) until the eccentric pin (Z2) can be pushed out. Swing the feed bar upright and take out the two screws (W2). Slide the feed lifting fork (Q2) upward and off, then lower the feed bar to a horizontal position and lift it off the eccentric block.

### To Remove the Looper Mechanism

Loosen screws (EE and FF, Fig. 16), remove the needle guard and the needle guard holder (AA, Fig. 15). Loosen the clamping screw (CC, Fig. 15) and remove the looper holder from the looper shaft. Loosen the clamping screws (L2 and Y2, Fig. 21) in the looper driving arm and the adjustable collar. The looper shaft may be withdrawn through the needle guard holder opening at the looper end of the bed.

Genuine Singer Needles should be used  
in Singer Machines.  
These Needles and their Containers  
are marked with the  
Company's Trade Mark "SIMANCO." 1

Needles in Containers marked  
"For Singer Machines"  
are not Singer made needles. 2